



AFTERMARKET

Connecting today
with tomorrow.

#futureproofed



Welcome to ZF Aftermarket.



- 4 Futureproof your business with ZF Aftermarket.
- 6 ZF Aftermarket: The facts.
- 8 We put the power in your hands.
- 10 Innovative solutions across industries.
- 12 Leading premium brands, engineered for excellence.
- 14 Innovation in every component.
- 16 World-class services.
- 18 Our workshop services.
- 20 Our Global Service Network: Always customer focused.
- 22 OPENMATICS: Connecting you to the future.
- 24 E-Mobility expertise: Equipped for whatever the future may bring.
- 26 ZF Aftermarket: The future is now.





Futureproof your business with ZF Aftermarket.





The world is moving faster than ever. This is an exciting time, and offers great opportunities for businesses that have the foresight, vision and long-term thinking to embrace change and to lead it. Partnering with a global leader like ZF Aftermarket is essential for ensuring your success.

The ZF Group.

ZF is a powerhouse of innovation and expertise in mechanical and digital technology that has been at the forefront of technological leadership for over 100 years, pioneering intelligent solutions for the automotive sector and industry. ZF's objective is to achieve 'Vision Zero' – a truly mobile world with zero emissions and zero accidents. And to create intelligent mechatronic systems that allow vehicles to **see. think. act.**

ZF Aftermarket.

As the world's leading supplier in the automotive and industrial aftermarket, ZF Aftermarket ensures that ZF's unmatched OEM expertise, knowledge and innovation is consistently carried forward. We are an innovative, forward-thinking partner, offering an exceptional product range built on the foundation of the trusted brands ZF, LEMFÖRDER, SACHS and TRW – and we continue to set the pace with smart services and tailored digital solutions to turn every challenge into an opportunity. Backed by industry-leading, forward-thinking research and development, we define and embrace the latest technology to ensure the aftermarket is **futureproofed.**

ZF Aftermarket: The facts.

Global leader with turnover of over

€ 3 billion

We operate worldwide in

120 locations
40 countries

We offer global coverage with our

90
logistics centers

8 000 employees

taking care of our customers





Our longest customer relationship
has lasted for over

◎ **100** years

Strong presence in the markets
we serve with over

◎ **650** ZF
service partners

◎ **6 500**
workshops

benefit from our dedicated ZF [pro]Tech
workshop concept

◎ **12 000** training participants

around the world

We put the power in your hands.

How do our three core values help you to futureproof your business?



Innovation.

Vehicles will continue to develop and become smarter, requiring new services and updates. Innovations brought to you by ZF Aftermarket can help you capitalize on these unmissable opportunities.



Pace and digitalization.

The speed of change and digitalization of product sales and services will create a number of potential growth areas, we at ZF Aftermarket will help you take advantage of these.



Reliable partnership.

We are part of the ZF Group, which means that we will stay ahead of developments, enabling us to deliver products and services that help you overcome challenges, maximize opportunities and stay profitable in the future.



Innovative solutions across industries.



We're proud to be a trusted partner to so many businesses across so many industries. Whatever your business, we know and understand your needs and we're working to meet them right now, while anticipating what you'll need tomorrow.



Passenger cars and vans

Our range includes products for driveline, chassis, steering and braking. We bring OE quality replacement parts, efficiency, safety and service to today's aftermarket – and we'll continue to bring you the latest technology in the aftermarket of the future.



Trucks and buses

We are present in all markets for trucks and buses – from OE quality transmissions, driveline components and axles to braking, steering and suspension parts, offering a wide range of services and products that reduce both fuel consumption and running costs.



Motorcycles

We bring a constant stream of innovations to installers with the world-renowned brands SACHS and TRW; these include the very latest developments in technology for motorcycle brake systems and accessories, as well as clutches for optimum performance and safety.



Off-highway

We offer preventative overhauls, upgrades and repairs that restore construction and agricultural machinery to original equipment quality, plus digital diagnostics for cost-effective maintenance and enhanced driving dynamics.



Rail

We deliver a complete portfolio of services for rail vehicles, offering preventative overhaul, maintenance and repair, as well as driveline and chassis technology conversion and retrofitting for rail vehicles.



Marine

We are a worldwide leader in marine propulsion systems. We supply innovative technical solutions for a wide range of marine applications, from motor boats, sail boats and superyachts to large commercial and government vessels, offering professional advice on all marine driveline technology, marine transmissions and more.



To discover more visit aftermarket.zf.com

Leading premium brands, engineered for excellence.

Every single one of our renowned brands is a recognized expert provider with a proud heritage and set of specialisms that makes them unique.



Leading the world in the supply of original equipment.

ZF offers a complete range of OE products for reducing fuel consumption, lowering CO₂ emissions and ensuring reliable care over a vehicle's entire service life, from parts for transmissions and axles for PC, CV and off-highway vehicles to oil change kits, lubricants and oil filters. Replacement units provide a fast, low-cost, environmentally-friendly solution with quality and reliability assured.



Quality. Performance. Reliability.

SACHS is the market leader in OE for shock absorbers and clutches. With a strong background in motorsports and over 120 years of experience, SACHS has proven that it provides premium quality with exceptional performance, even under the most extreme circumstances. Our parts prove their strength even in challenging applications such as snow ploughs and cable cars.



Pioneering. Precision. OE heritage.

LEMFÖRDER is the number one brand in OE steering and chassis components. It has been a leader in developing innovative PC, CV and off-road chassis technology for over 70 years. A trusted partner of over 50 vehicle manufacturers worldwide, LEMFÖRDER is known for its pioneering spirit and attention to detail, rigorously testing every part and setting the highest standards in steering and suspension.



Energy. Excellence. Empathy.

TRW branded products cover 98% of the European vehicle parc, offering coverage that is as unrivaled as its reputation and expertise in braking and suspension. TRW has been a renowned automotive safety brand for over 100 years and is backed by a global network of true aftermarket experts.



Innovation in every component.

We offer an extensive portfolio of aftermarket parts across our brands, perfect for almost any vehicle.

Motorcycle



Passenger Car

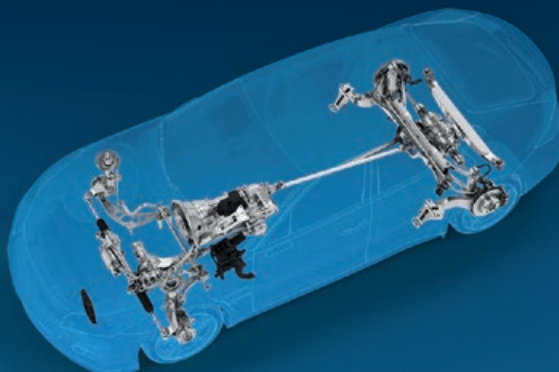

Van

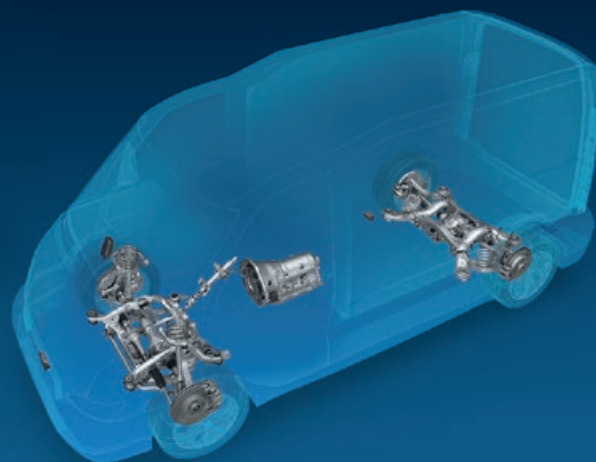

Rail

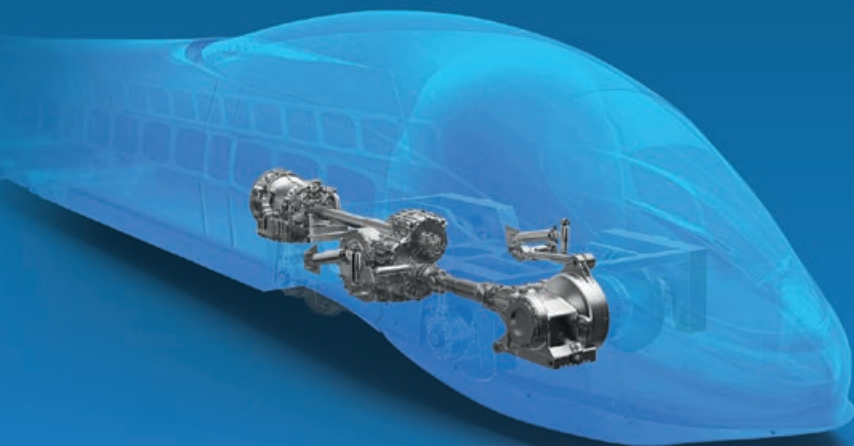

Off-Highway

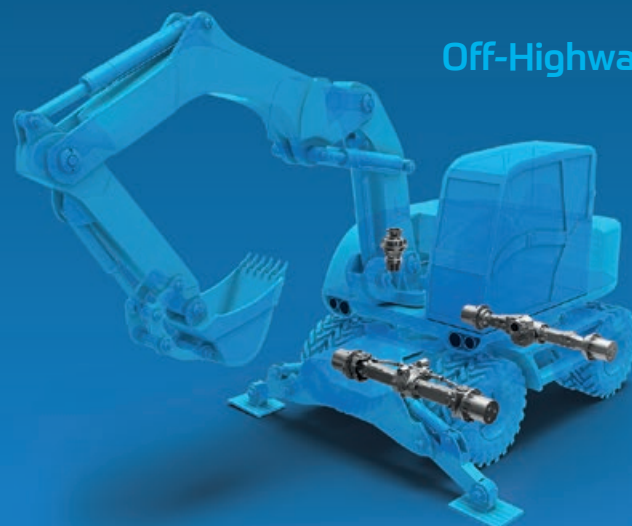

Truck

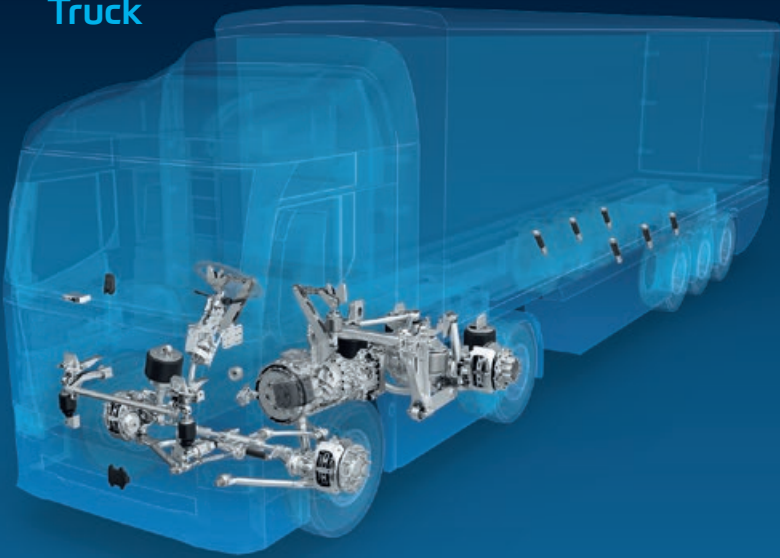

Bus

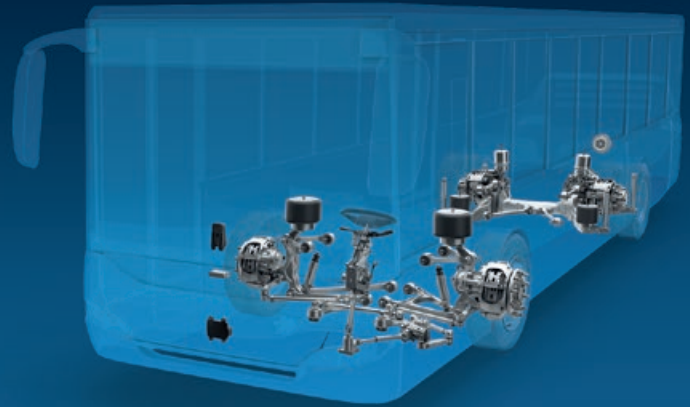

Marine

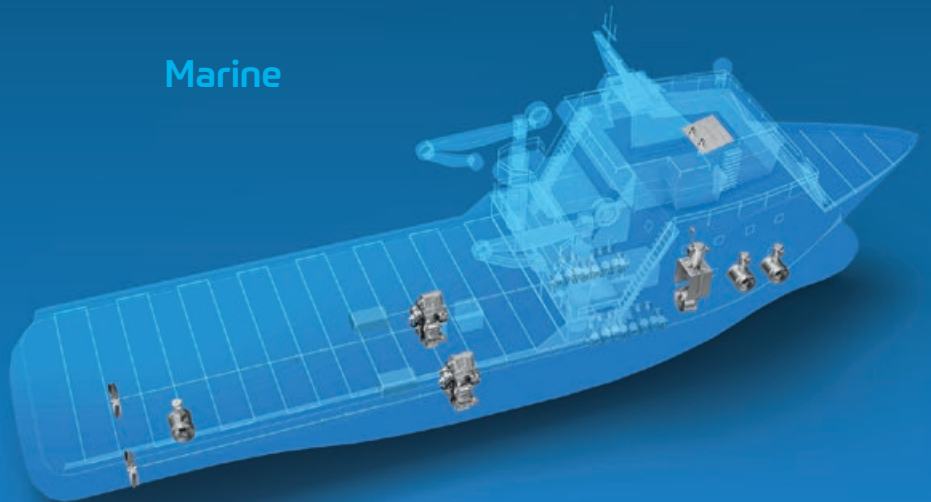
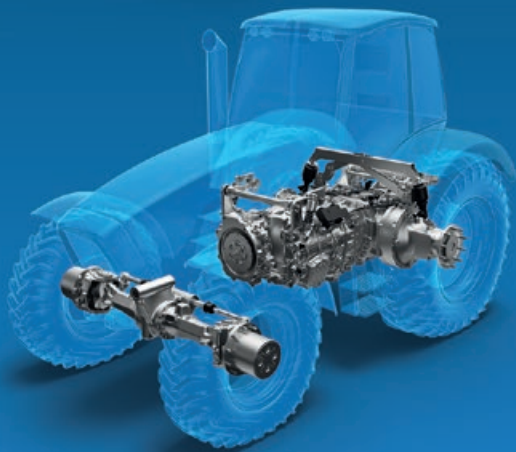

World-class services.

We'll be there when you need us: ZF Aftermarket supports you with an extensive service network and an entire range of aftersales products and added value services, from prompt, genuine parts supply with technical servicing, through to consultancy and training.

We provide a truly comprehensive solution by offering integrated services for the entire driveline and chassis system as well as for active and passive safety technology from a single source.





Maintenance and Repair.

From preventive overhaul and conversion to retrofitting for more efficiency, comfort and safety, our dedicated repair offers give you the reliability you need to be able to plan your vehicle maintenance service precisely, enabling you to satisfy your customers.



Services for fleets.

We provide totally customized service packages, including service contracts, diagnostic systems for computer-based monitoring of electronically controlled ZF products, customized training and consulting, specially tailored to fleet operators' needs for seamless management of vehicle fleets. With OPENMATICS, driver safety, security and comfort are increased, processes optimized and value is added in every way.



Remanufacturing.

Our remanufacturing program is closing the gap between shorter product innovation cycles and longer product life cycles in ways that are as cost-effective as they are environmentally friendly. High-quality remanufactured components from ZF Aftermarket are cutting-edge and actively contribute to environmental protection by using up to 90% less material in comparison to the manufacture of a new product.



Logistics and eServices.

Thanks to our powerful logistics and state-of-the-art information technology, we ensure that processes are consistent throughout our central warehouses in Germany and regional distribution centers all over the world. Supported by sophisticated eCommerce solutions, we can handle your requests quickly, reliably and on schedule worldwide. This results in services which are optimized, with high-quality, quick and flexible deliveries around the globe.

Our workshop services.

ZF [pro]Tech and ZF [pro]Points provide leading expertise and many benefits to passenger car and commercial vehicle workshops.

Knowledge is power. Access ours with ZF [pro]Tech.

We're helping our installers futureproof their workshops with ZF [pro]Tech. ZF [pro]Tech allows workshops to access the latest technical information from one of the world's largest automobile parts manufacturers via personal contact, technical training sessions and our service-focused online portal.

You can use ZF Aftermarket's expert knowledge across our brands ZF, LEMFÖRDER, SACHS and TRW to increase your effectiveness and service quality.

direct industry contact + premium product quality = the foundations for equipping partner workshops with the best foundation for the future.



Discover more at protech.zf.com





Loyalty deserves to be rewarded: ZF [pro]Points.

We created ZF [pro]Points as part of the rewarding relationship we seek to continually build with our workshop customers. Our online loyalty program ZF [pro]Points rewards workshops for using ZF Aftermarket products and at the same time, supports them in their business.

ZF [pro]Points allows customers to earn loyalty Points whenever they purchase any ZF, LEMFÖRDER, SACHS or TRW branded products and offers a wide range of outstanding rewards: from consumer electronics to useful workshop equipment.



Discover more at zf-propoints.com

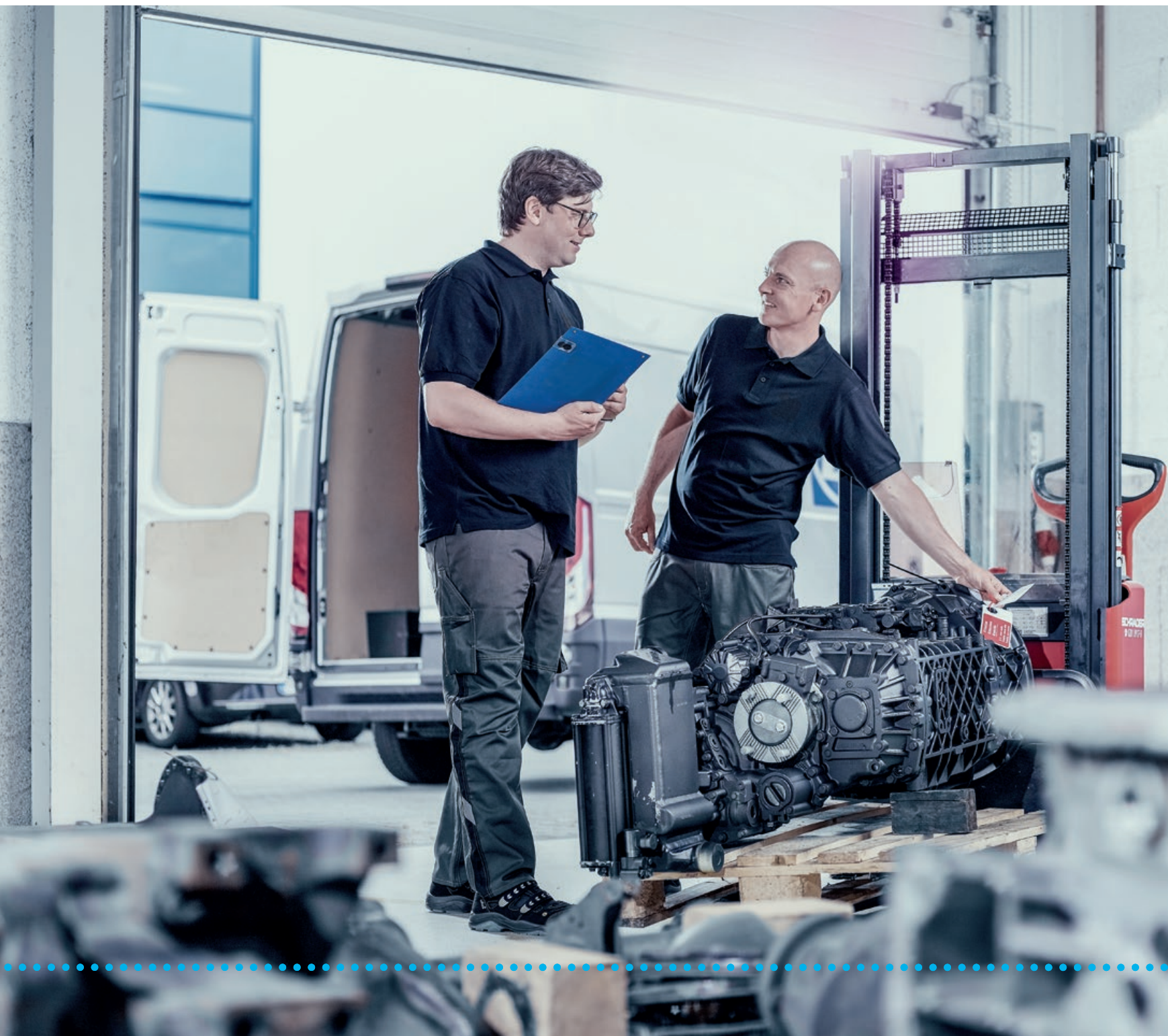

Our Global Service Network: Always customer focused.

As a leading supplier of driveline and chassis technology, we provide products and services which ensure personal support is available anywhere, at any time. This is our Global Service Network – there's no better example of our futureproof thinking.

With a dedicated network of 650 service partners, service points and ZF's own service locations, our Global Service Network provides customers with unrivaled support and individual solutions, ensuring speedy availability and maximum service quality at all times.

Our Global Service Network provides a comprehensive repair service, high-quality products and technical systems expertise, thus ensuring customer mobility worldwide and throughout a vehicle's entire service life.



Locate your closest ZF service partner at zf.com/serviceNetwork

OPENMATICS: Connecting you to the future.



Businesses all over the world trust ZF Aftermarket because we bring them the latest innovations and keep them connected to the future. OPENMATICS is a shining example of this.



With our OPENMATICS' open connectivity IoT platform, we supply the best uniform standard for secure, flexible and reliable networking for several industries worldwide, without systemic or technological barriers.



Our Telematics solution provides vehicle-specific data that enables fleets to operate at maximum efficiency while reducing fuel consumption and maintenance costs for their vehicles and journeys, plus vehicle diagnostics that detect malfunctions while identifying potential areas for improvement.



Discover more at openmatics.com



Our Asset Tracking solution ensures full traceability throughout the entire logistics process, and the deTAGtive Call Button enables you to keep track of material procurement in the production environment, creating an interactive all-in-one solution for intralogistics.



Our OPENMATICS solutions enable our customers and partners to intelligently connect their businesses around the world; this is just one example of how we deliver innovation and forward-thinking solutions to our partners, enabling them to futureproof their business for tomorrow.

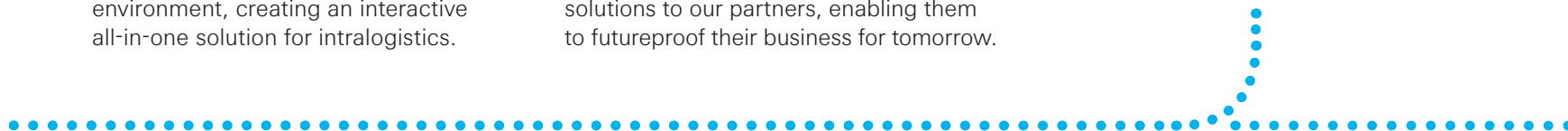

E-Mobility expertise: Equipped for whatever the future may bring.

In today's ever-changing automotive and industrial landscapes, with emerging new technologies, global megatrends and broader application requirements than ever, it is becoming increasingly critical to access a range of services to keep ahead of the curve.

When you choose ZF, you have access to our intelligent electric drive solutions from electric motors and plug-in hybrid transmissions to power electronics and all-electric drives, brakes and chassis components. Our solutions cover vehicles and non-automotive applications, so whatever your focus we can help your business face the future.

Plus, benefit from our high-voltage training courses and technical knowledge in original equipment for hybrid electric vehicles. Available to authorized ZF service partners, independent workshops, appointed workshops, fleet operators and vehicle or parts manufacturers. E-Mobility training is

given in the form of modular courses, with each module being as informative as it is invaluable, giving you the necessary skills to handle hybrid drives, electric drives and fuel cells safely.

OPENMATICS E-Mobility portfolio (apps, business intelligence reports and a Bach Onboard Unit) gives you complete connectivity and fleet management services for electric bus, truck or off-highway fleets. The core benefit for customers is the concept of an open platform with various API's and Software Development Kit allowing third parties to develop their own apps to run on the platform.





ZF Aftermarket: The future is now.

Whatever your need, whatever your goal, you can trust ZF Aftermarket to deliver. We bring you an unparalleled range of OE quality products and service solutions to keep your business ahead today, while delivering the forward-thinking, futureproof innovations and vision of tomorrow for Next Generation Mobility.





ZF Group

ZF Aftermarket

info.zf-aftermarket@zf.com

aftermarket.zf.com



twitter.com/zf_group
facebook.com/zfgroup.global
youtube.com/zfriedrichshafenag