

The image shows a large, modern industrial building with a prominent brick and glass facade. The word "MEYLE" is visible on the building's exterior. In the foreground, there is a tall, slender monument with a statue on top, set on a circular base. The scene is set against a blue sky with scattered white clouds. A semi-transparent white box is overlaid on the right side of the image, containing the title text. At the bottom, there is a dark blue banner with white text and the MEYLE logo.

MEYLE Company Presentation

DRIVER'S BEST FRIEND

MEYLE

As reliable as a friend, MEYLE supports the independent automotive aftermarket with better parts and solutions

Better parts than OE as well as better solutions for wholesalers and workshops



Superior manufacturing and sourcing capabilities focused upon the IAM



Reliable product, data, service, pricing and distribution for long-term partnerships



We work with our partners to make mechanics ... Driver's Best Friend.



MEYLE Vision:

“Every competent car technician around the world prefers MEYLE as the premier automotive aftermarket brand.”

**- Karl Gaertner, Classics enthusiast and CEO
“MEYLE AG“ & “Wulf Gaertner Autoparts“**

As reliable as a friend, MEYLE supports the independent automotive aftermarket with better parts and solutions

Company Introduction – who we are

Marketing Strategy – building our brand

Sales Strategy – reliable as a friend

Product Portfolio – better parts and solutions



As reliable as a friend, MEYLE supports the independent automotive aftermarket with better parts and solutions

Company Introduction – who we are

Marketing Strategy – building our brand

Sales Strategy – reliable as a friend

Product Portfolio – better parts and solutions





MEYLE foundation:

**“The friendship of those we serve
is the foundation of our success.”**

**- Wulf Gaertner, race driving enthusiast and
founder “Wulf Gaertner Autoparts“**

While always innovative, we have evolved from auto-part trader to manufacturer of better parts to premium brand in the automotive aftermarket focused upon solutions

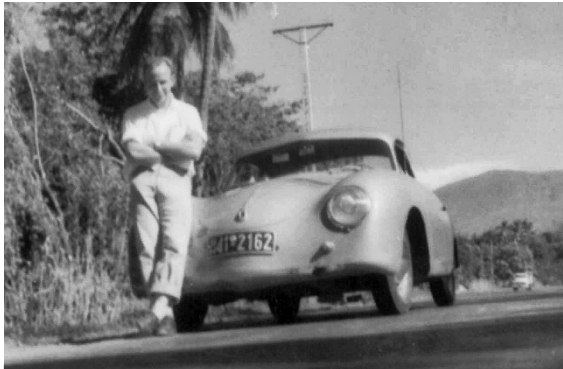

1958-1995: Providing global access to OE parts



1995-2016: Manufacturing better products than OE



2016-today: Global brand focused upon better solutions

Thus, we know the difference between a repacker and a manufacturer like us

Repacker

Knows no specification.

Buys, sells, and keeps fingers crossed.



Manufacturer

Engineers set and QM ensures specifications and standards.

Ships according to specification every time.

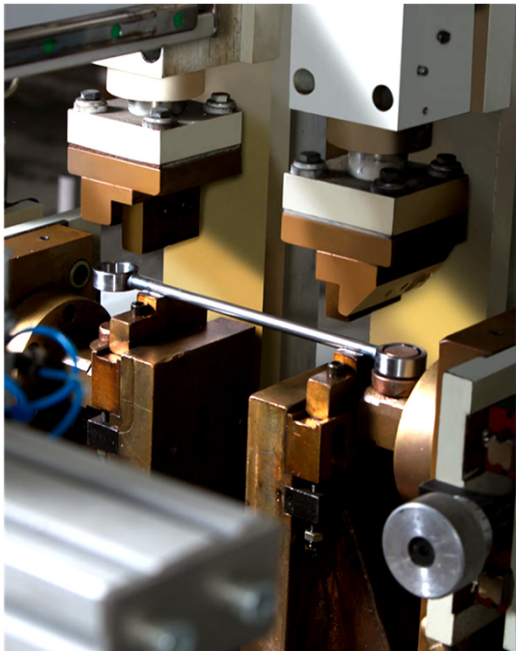

We manufacture around the world in the best factories for the aftermarket according to the highest standards: our own.



**Made by MEYLE.
Engineered and quality approved in Germany.
Manufactured worldwide.**

Company Introduction: Capabilities

MEYLE

Our factories are best-in-class independent aftermarket operations, certified to supply OEM-parts

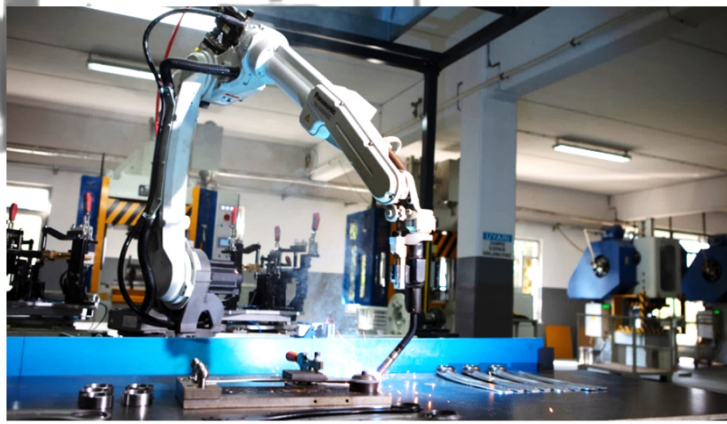
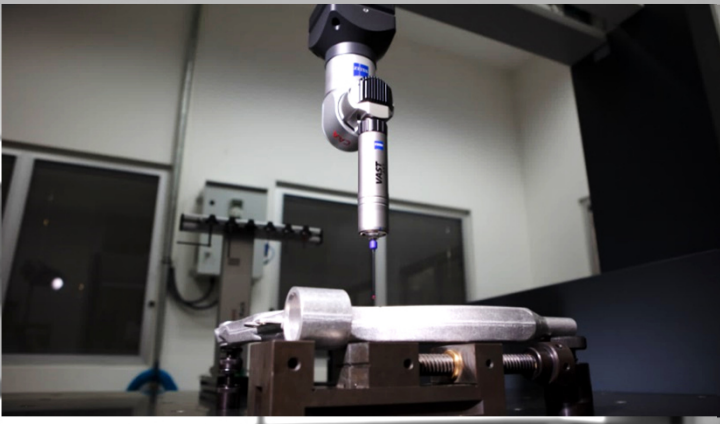

We manufacture better parts ... each and every time



R&D: >30 engineers, researching and specifying product requirements and capabilities @ headquarters and in factories



QM: >20 Quality Managers ensuring part conformity to engineers' specifications



Manufacturing: In-house steering, suspension, rubber-to-metal part factories and a strategic base of OE-suppliers



Logistics: >95% fill rate at 29.000 m² storage space with 56.000 pallet slots supporting 12.000 picks per day

Our company structure is focused upon supporting the aftermarket – today and in the future



"We are aware of our responsibility for people, planet & profitability and based on this understanding aim to act both sustainable and innovative."

- MEYLE is **aware of the need to act upon climate change**, energy transition, future scarcity of resources and alternative drive systems. Thus Corporate Responsibility needs to be at the core of our decisions and value chain.
- We are **guided by balancing the interests of people, planet, and profit** and the **17 UN Sustainable Development Goals (SDGs)** in pursuing measures to achieve a sustainable and efficient value creation.
- We **develop better parts and solutions to keep vehicles on the road longer**. This way, we offer motorists more sustainable solutions for auto repair and maintenance and support the efficient use of resources in vehicles.



Our focus on sustainable growth instead of short-term measures is working: at our headquarters in Hamburg, we have grown ten-fold* over the past 16 years



Today, we are a global, family-owned and run enterprise with >1.000 employees

* from 3,635 to 38,425 square meters

We support turnover with our strong brand for fast sell-through

Company Introduction – who we are

Marketing Strategy – building our brand

Sales Strategy – reliable as a friend

Product Portfolio – better parts and solutions



Our two primary target groups are opinion leaders in their fields who appreciate better parts and smarter solutions

Joy of Maintaining & Fixing

Technicians rely on MEYLE for:

- Better, longer lasting parts in >11 categories
- Smarter repair kits and solutions
- Reliable data and information
- Workshop know-how and transfer
- Multiple specifications for service orientation
- Satisfied customers



MEYLE PERFORMANCE



Rush of Acceleration

Car enthusiasts rely on MEYLE for:

- Better, longer lasting parts in >11 categories
- Performance engineering team supporting high-requirements with low volumes
- Development of 3D-printing capability
- Car enthusiasts supporting car enthusiasts



MEYLE

DRIVER'S BEST FRIEND

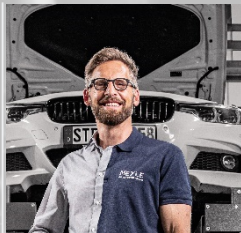

We support the
**joy of maintaining
and fixing friends
on wheels.**

We grow into leading social media channels in the IAM:



Since Mid 2019 we are communicating efficient solutions created from technicians' perspective as „MEYLE-KITS“



- From the perspective of the technician, we deliver **smart alternatives to common OE maintenance** approaches
- MEYLE-KITS save time and money by **making maintaining and repairing more simple and affordable**
- Our „Highlight“-KITS are **smarter than OE** – changing conventional ways to repair

MEYLE-KITS: Better solutions ...

Award-winning!

And ...

The one ...

Clever ...

Right on ...

Less ...

...for you!
MEYLE-KITS save time and money and make the daily workshop life more efficient. They make it much simpler and more affordable to tighten bolts and make repairs. This also optimizes the car life capacities and ensures satisfied customers. When it comes to developing MEYLE-KITS, we take the perspective of the workshop employees and are committed to making workshop operations as efficient and fast as possible.

Learn more at www.meyle.com/en/meyle-kits

Follow us on

DRIVER'S BEST FRIEND **MEYLE**



SL TRUCKSPORT 30

We support car enthusiasts, driven by the rush of acceleration.

We grow into leading social media channels in the IAM:



Marketing Strategy: MEYLE Performance

MEYLE PERFORMANCE

Our engineering and quality capabilities made us Tier-1 and development partner of MORGAN



Premium parts for hand-built vehicles:
We supply steering and suspension parts to
Great Britain's most exclusive car maker



Marketing Strategy: Tier-1 Supplier

MEYLE

With a global brand strategy, a dedicated marketing team, and relevant content, we will continue to grow with strategic partners

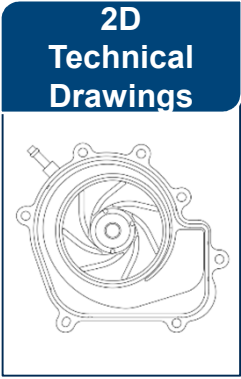
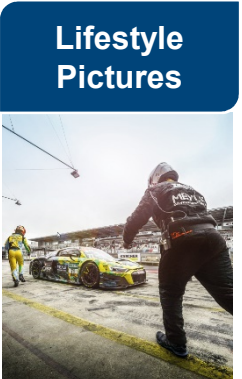
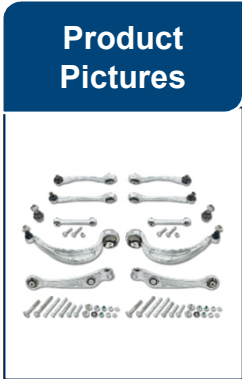
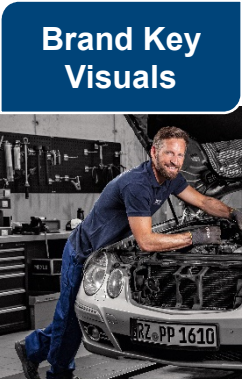

MEYLE supports turnover and profitability in the aftermarket with our strategic approach to selling

Company Introduction – who we are

Marketing Strategy – building our brand

Sales Strategy – reliable as a friend

Product Portfolio – better parts and solutions



Three macro trends are shaping our market. We will utilize these to continue to grow sustainably

Consolidation re-shuffles the market landscape



Digitalisation increases efficiency



Maturing online channels drive pricing transparency



MEYLE strategy: Further build BRAND - go DIGITAL - execute COMMERCIAL POLICY

Sales Strategy: Commercial Policy

MEYLE

We continue to proudly serve workshops in more than 120 countries, but...



Sales Strategy: Commercial Policy

MEYLE

...we are also working towards becoming the most reliable partner in the aftersales market

Via **selective distribution** we aim to maximize value creation and to minimize value destruction.

We have implemented **global pricing management** to reach adequate conditioning per retailer type.

We create **value over volume** with better products and aim for **best-in-class aftermarket service**.



We run best-in-class aftermarket service for our partners on multiple axis to maximize service and profitability...



Regional Account Managers and Sales Representatives



Local language customer support office



Qualitative Data Specialists



Sales Marketing Services & Concepts

We want to become your partner that focuses value maximization over price discussions

We are investing in our digital and marketing capabilities to **support premium price point realization**.

We look to **cooperate on goods movement and rotation rates**: when can we start “Vendor-managed Inventory (VMI)” with you?

We look to **focus our partnerships** upon those traders that look to design the future of our shared market on a pay-for-performance basis.

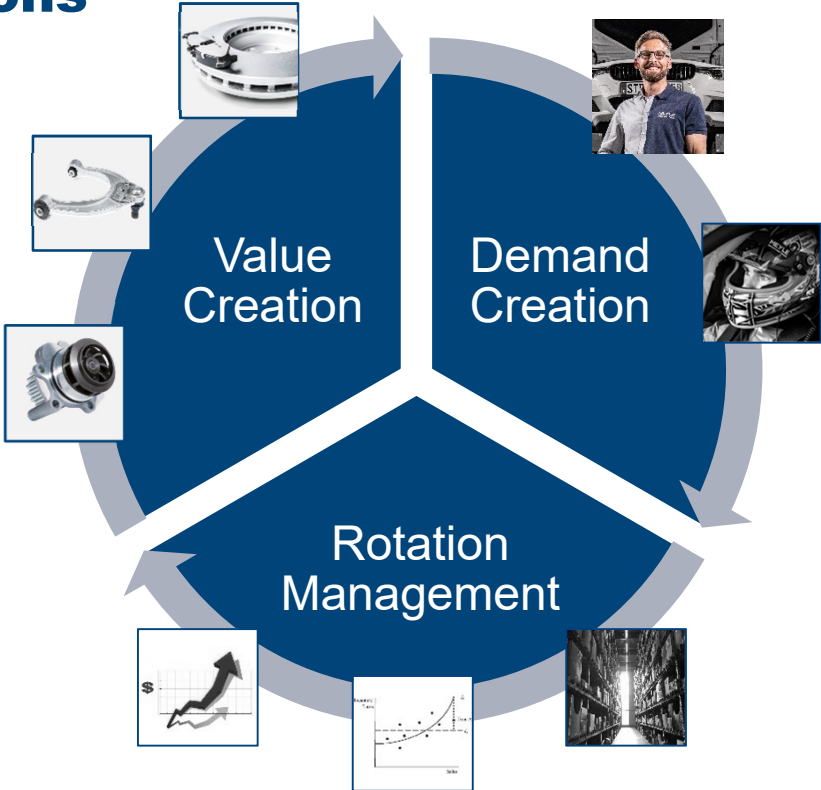

As reliable as a friend, MEYLE supports the independent automotive aftermarket with better parts and solutions

Company Introduction – who we are

Marketing Strategy – building our brand

Sales Strategy – reliable as a friend

Product Portfolio – better parts and solutions



We supply parts in three standard product lines that support original replacement as well as the very highest standards



True to OE.

~ 21,000 parts for cars, vans and trucks

Manufactured according to MEYLE specifications and standards



Performance Design: Advanced performance and design

~ 1,200 products with more performant features than the original



High Durability: Better than OE.

>1,250 parts

Technically improved parts for extra service life

4-year-guarantee

MEYLE-ORIGINAL: True to OE - manufactured according to MEYLE specifications and standards



- For our focus categories, we are **ensuring and expanding market leading coverage rates** in Europe (and for European makes outside of Europe) with **more than 21,000 spare parts** for passenger cars, vans and trucks
- MEYLE-ORIGINAL is quality tested, robust, and durable due to our **high standards that also allow us to access OE-solutions** to increase our coverage rates
- Our „True-to-OE“ quality level, which is well above the entry segment of the market, mandates this product line to be **positioned competitively against other world-renowned IAM brands**



MEYLE-PD: Performance Design. Car parts with advanced performance and design



- Products of the MEYLE-PD product line fit like OE, but are performing better than the comparable OE product.
- ~ 1,200 MEYLE-PD parts in the brake and filter categories **set standards in comfort and functionality.**
- These advanced products are **more than competitive** and positioned above our MEYLE ORIGINAL product line with a value-based pricing strategy.



MEYLE-HD: Better than OE. Technically refined parts with a 4-year guarantee.



- Driven by an increase of vehicle-recalls in the early 2000s and supported by our manufacturing capabilities, we developed **our re-engineering process to yield car parts that are technically superior to the OE counterpart**
- **Reinforced and improved designs** as well as high quality materials make MEYLE-HD parts more durable and reliable: They **simply last longer**
- The product line encompasses >1.250 parts and is **positioned in the premium segment** of the market



MEYLE-HD: Our re-engineering process has allowed us to grow our manufacturing capabilities in many categories

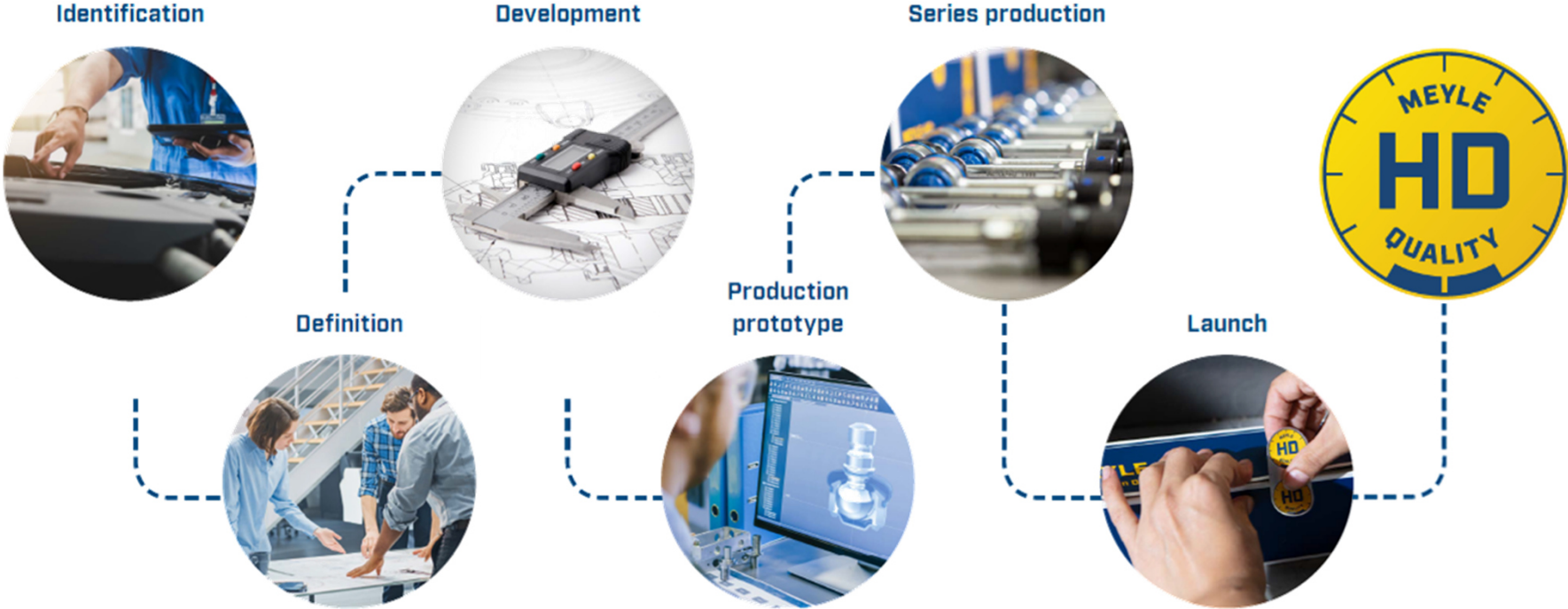

While we offer ~24.000 reliable spare parts in total, we are aiming at strategic supplier status in following (sub-) categories:

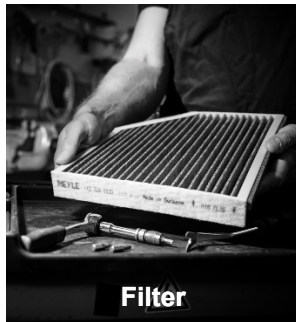
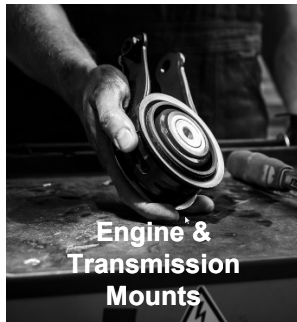
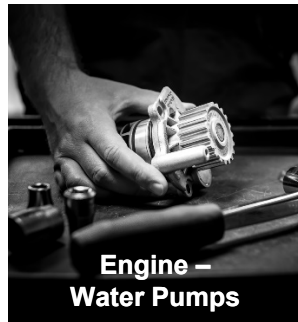
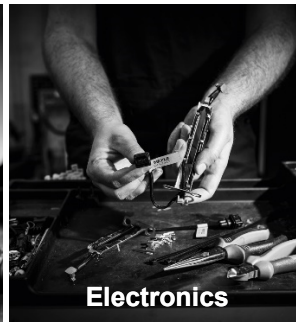
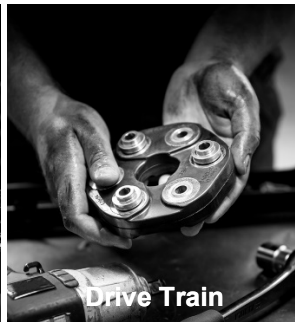
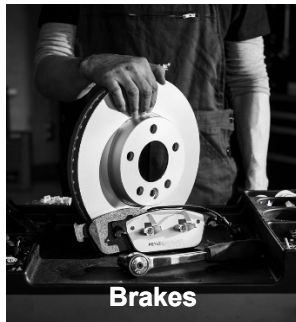
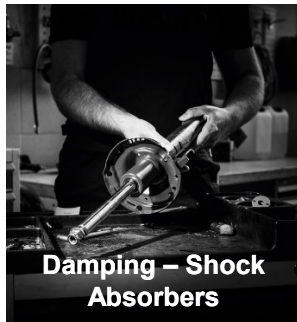
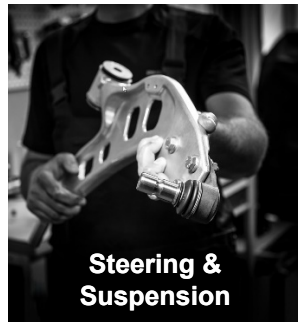

While we offer ~24.000 reliable spare parts in total, we are aiming at strategic supplier status in following (sub-) categories:



MEYLE steering & suspension is your first choice full portfolio supplier with better parts and solutions than OE

Manufacturing competence



- Manufacturer of high quality steering & suspension parts with **25 years of engineering know-how**
- **Motorsport approved:** We are engineering, developing and testing in collaboration with motorsport teams

Better parts



- MEYLE does it better: our **MEYLE-HD products are technically superior to OE** part with 4 years guarantee
- Our **quality department operates according to the highest standards in the IAM:** our own

Better solutions



- **Award winning MEYLE-KITS save time and money** in the daily workshop business
- Proposition development **according to market- and future trends**

Leading coverage rates



- **Leading coverage rates for European markets as well as European CarParcs outside Europe**
- Best in class coverage for strategic focus product groups
- Development ambition to be **adequate time-to-market**

MEYLE-HD quality characteristics in steering & suspension are manifold, but all support one objective: longer part lifetime

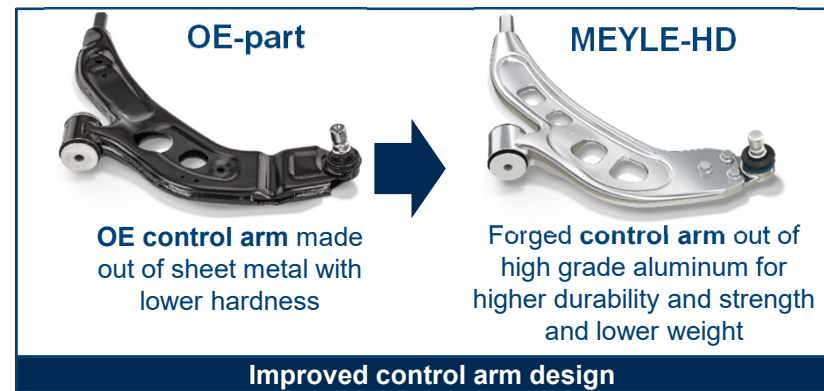
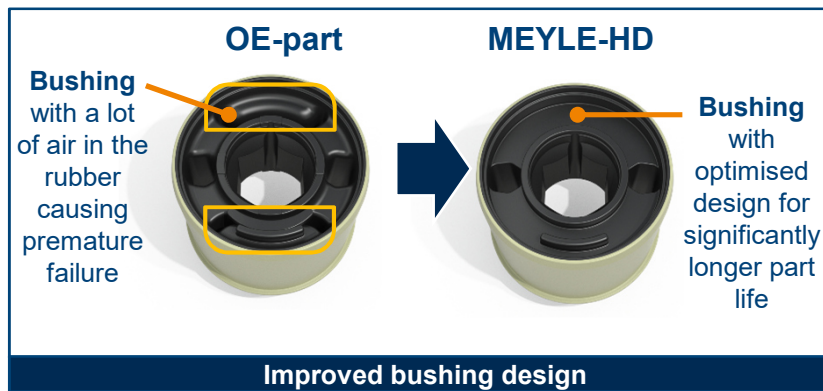
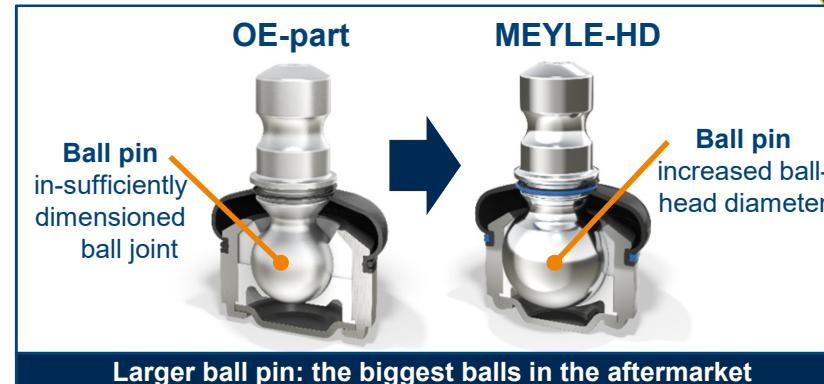
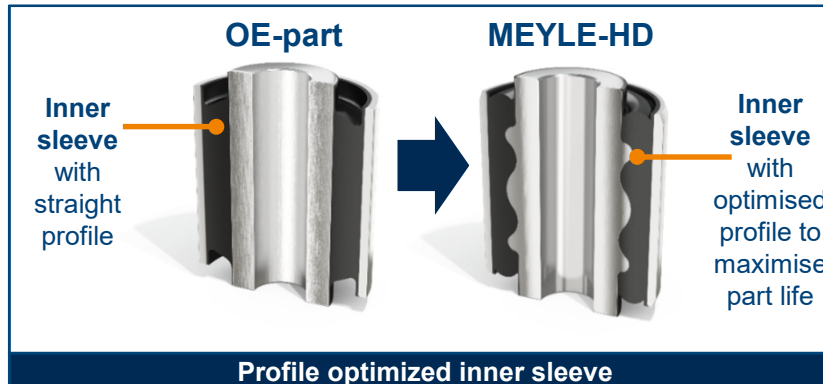

To improve part life, in some cases HD parts are completely re-engineered*

Reinforced forged body
x3 lifetime vs. OE

SMART Design
-25% lighter body

Premium Quality Accessories

Replaceable Ball-Joint
(OE not replaceable)

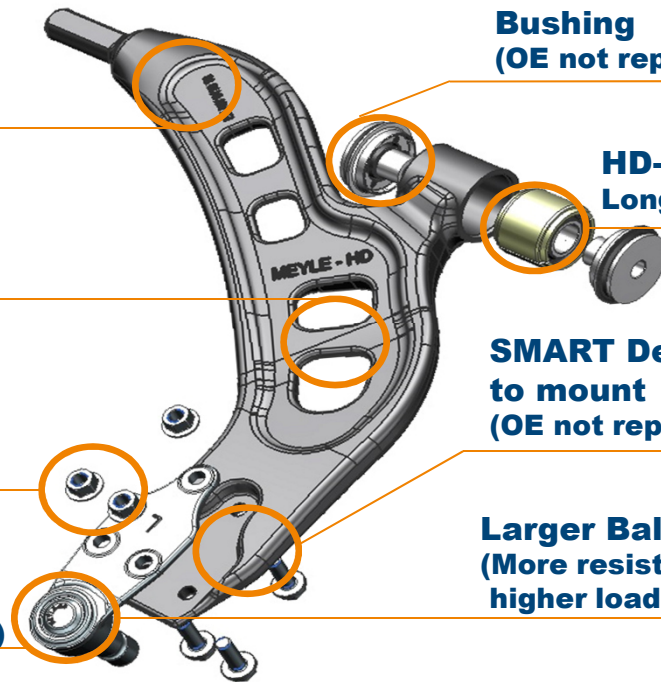

Bushing
(OE not replaceable)

HD-Bushing
Longer Warranty (x2)

SMART Design, easy to mount
(OE not replaceable)

Larger Ball-Pin
(More resistant to higher loads)

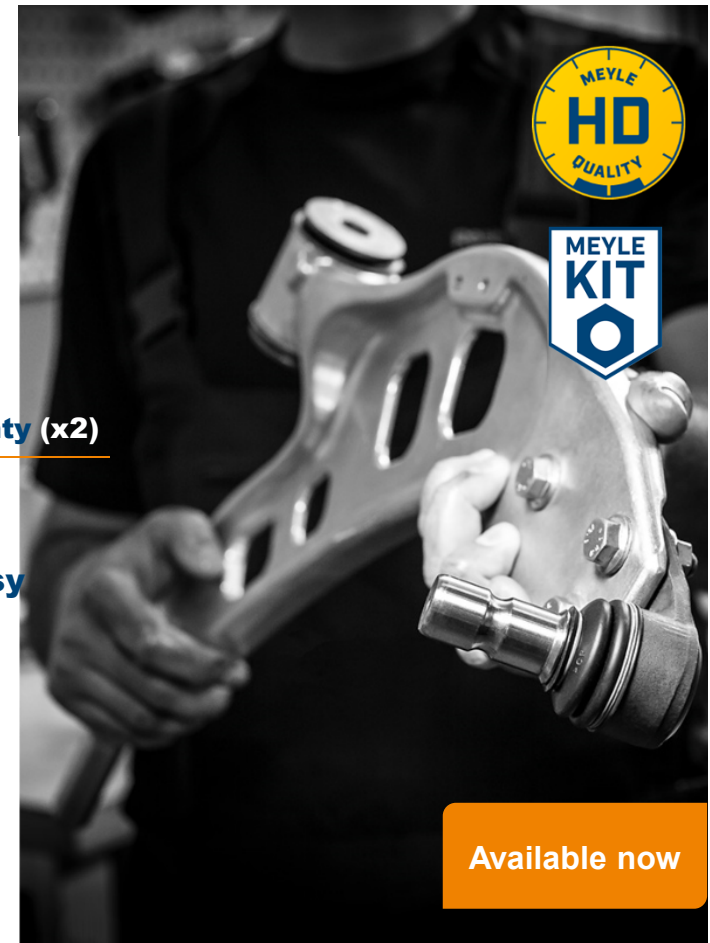

In steering & suspension, our engineers have developed many MEYLE-KITS, which often make our solutions “smarter than OE”



For example:

MEYLE hydraulic pump comes with appropriate oil

All-In:
Complicated job - all in one box

MEYLE-HD pre-compressed slotted bushings KIT

Component-Upgrade:
Replace broken components, not the whole part

automechanika
Innovation Award
Winner 2018

MEYLE-HD control arms with camber corrections

One-for-All:
One control arm replacing up to 3 OE control arms

While we offer ~24.000 reliable spare parts in total, we are aiming at strategic supplier status in following (sub-) categories:

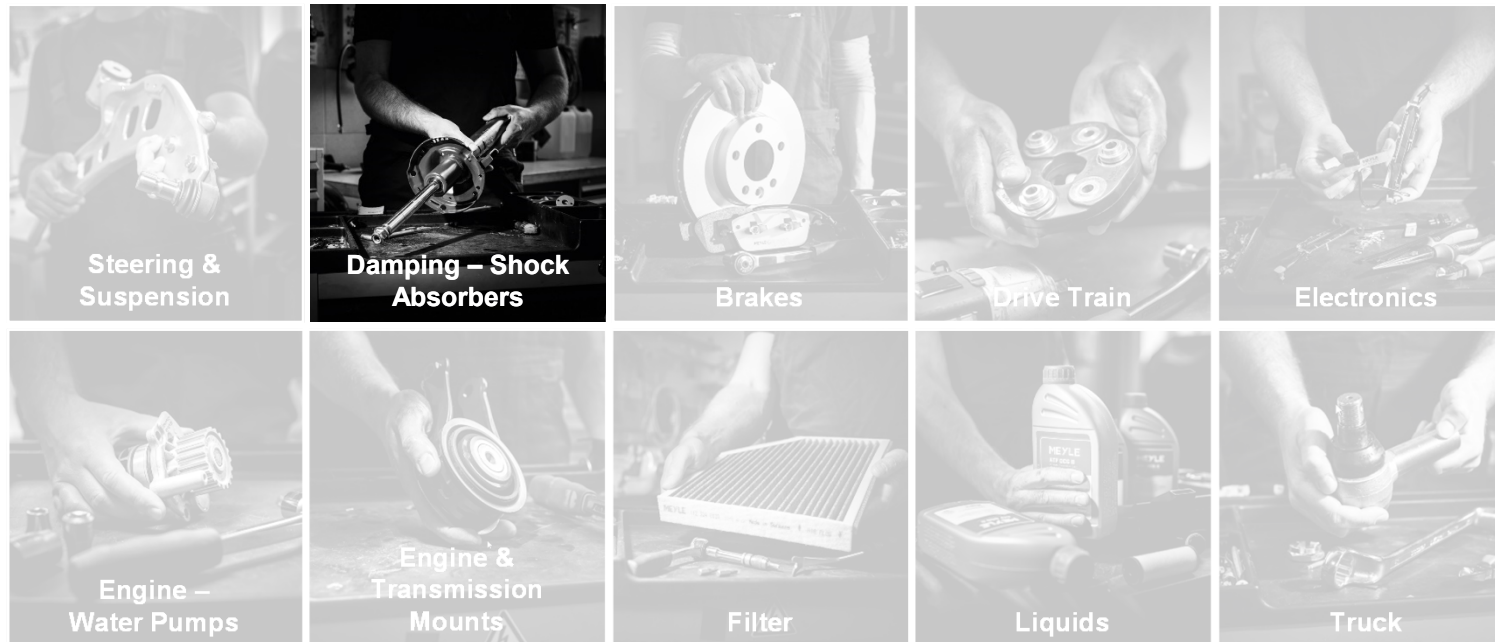

Today, the quality of MEYLE-ORIGINAL shock absorbers has developed into the best in the IAM

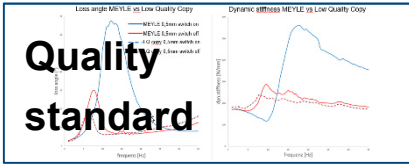

- Meets the high MEYLE standard:
- **Engineered and quality approved in Germany in accordance to VDA** (German Association of the Automotive Industry) testing specifications
 - **100% performance and leakage test** during production



Competitive coverage rates for European markets as well as European CarParcs outside Europe
(in select markets > 80%)



MEYLE brand promise throughout the category: MEYLE marking and packaging on all parts including batch and production data for a unified image



While we offer ~24.000 reliable spare parts in total, we are aiming at strategic supplier status in following (sub-) categories:

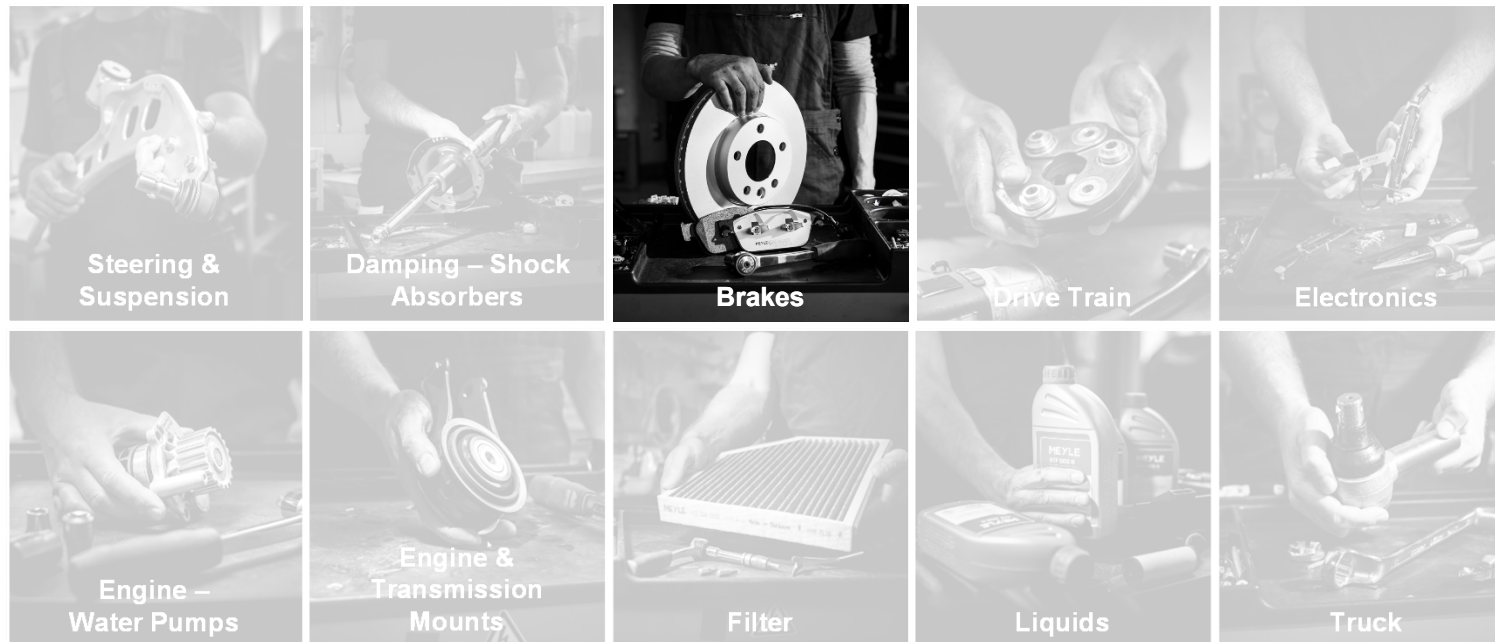

MEYLE brakes are your first second choice especially when you want to offer more than just „the same as OE“



- **20 years of expertise** in braking define our products
- **Individualised friction materials** for each and every brake system for optimal performance
- **Benchmark-proven** best-in-class applications



- MEYLE-PD brake products are **tailored to performance-oriented driver needs**: shiny discs and better performance for cars, longer lasting brake pads for LCVs.



- **MEYLE-KITS save time and money** in the daily workshop business, for example with >100 brake shoe kits



- **Leading coverage rates for European markets as well as European CarParcs outside Europe**
- Best in class coverage for strategic focus product groups

MEYLE-PD: Taking brakes to the next performance level for passenger cars, vans, and trucks



Advanced design and technology

~1.200
brake discs and pads equipped with
performance features

Meets and exceeds ECE R90
standard – shipping globally



The best mix of performance and
comfort for sportive drivers



Performance for extra longevity to
last the extra weight and distance



Performance for the greatest
demands and toughest conditions

MEYLE-PD brake pads deliver maximum braking performance with a short bedding-in time while operating silently and keeping wheels clean



Maximum braking performance:

- New friction materials for excellent and consistent friction coefficient as well as quick and excellent responsiveness



Short bedding-in time:

- Individualised friction materials and special brake pad coating* leads to short bedding-in time



Silent operation:

- Additional adhesive between shim and backing plate guarantees better bonding and leads to advanced damping properties to reduce noise
- Individual anti noise shims, slotting and chamfering designed for each brake pad further support a silent performance



Cleaner wheels:

- Advanced friction materials lead to less brake dust development



Meets and outperforms highest quality standards:

- Meets and exceeds ECE R90 regulation
- Free of heavy metal and copper

MEYLE-PD brake discs appear brilliantly with no degreasing needed while providing the highest driving comfort and resistance to toughest conditions



Brilliant appearance and no degreasing

- Brilliant appearance due to modern cutting-edge coating technology for long lasting anti-corrosion protection.
- No degreasing needed due to high-grade finish.



High resistance to “warping” under toughest conditions

- The carbon content of the grey cast iron (material of the brake disc) is increased by a special high carbonization (HC) process avoiding “warping”*.



Driving comfort

- Manufactured and proven to reach lowest values in disc thickness variation (DTV), runout, parallelism, which leads to elimination of any vibrations
- Each disc is fine balanced to eliminate imbalances preventing vibrations



Meets and outperforms highest quality and service standards:

- ECE R90 certified as required
- 99% with locating screw

*applied when necessary

While we offer ~24.000 reliable spare parts in total, we are aiming at strategic supplier status in following (sub-) categories:

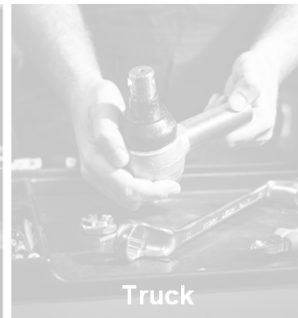
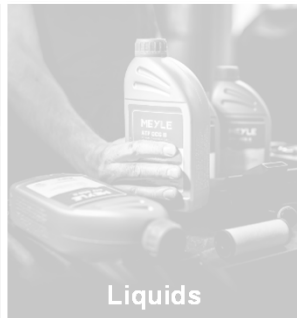
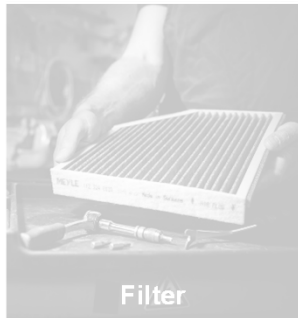
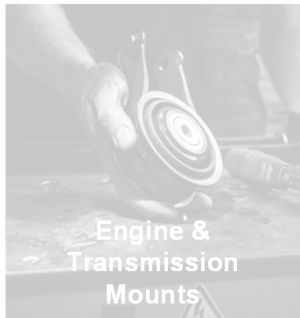
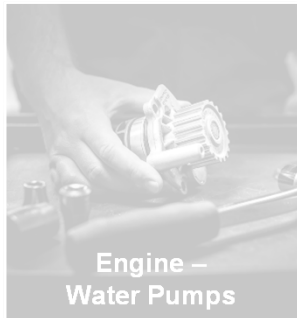
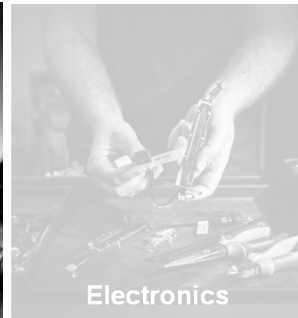
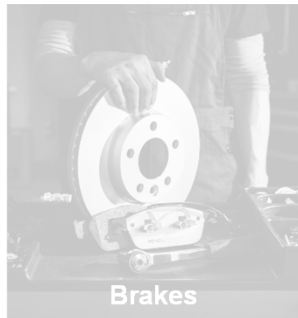
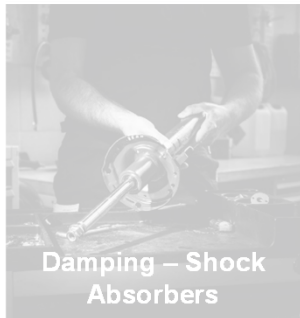

In the „Drive Train“ category, we are focusing upon fast-moving replacement parts while adding value through MEYLE-KITS and MEYLE-HD flex discs

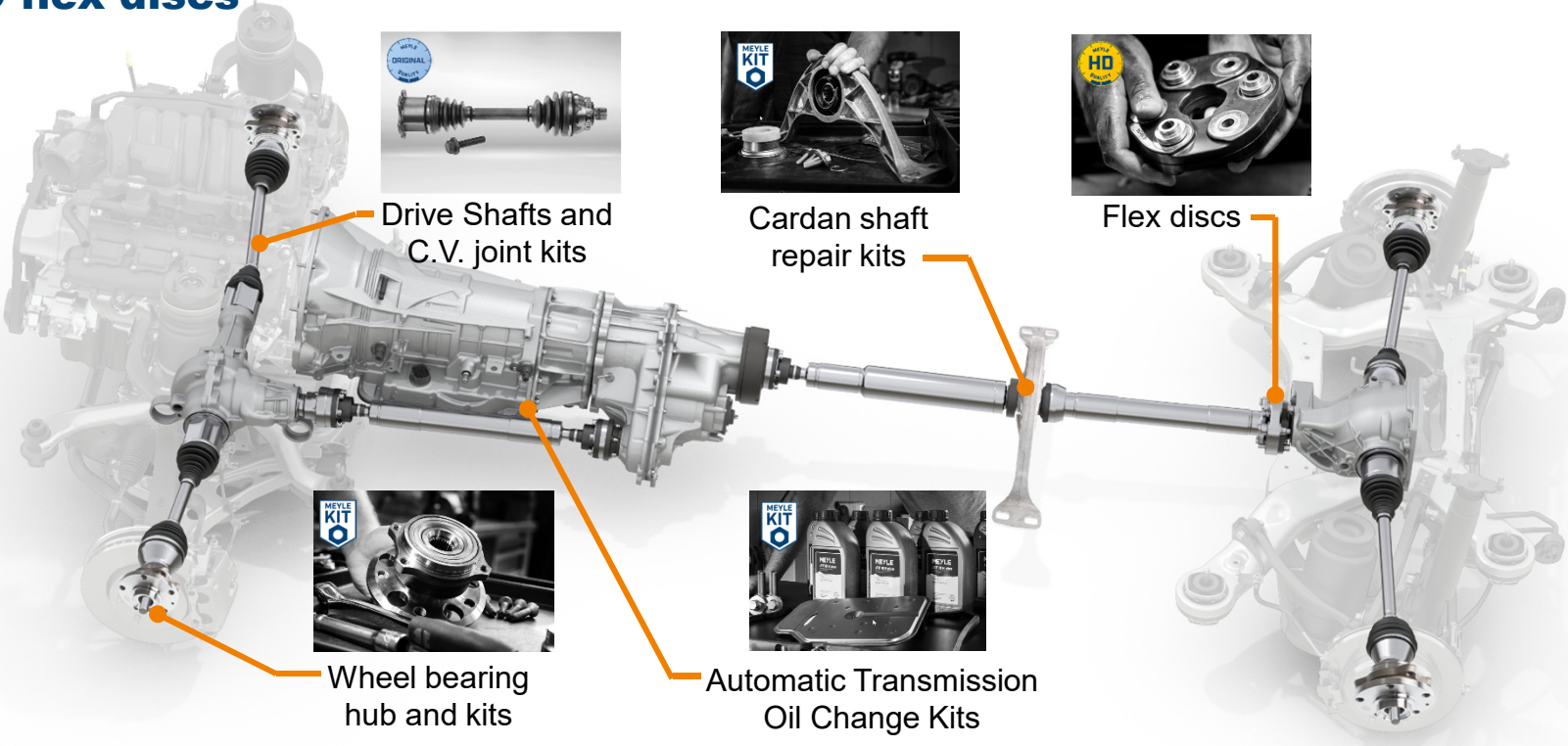

Our rubber-to-metal manufacturing competence and our approach to „smarter solutions than OE“ are important to our Drive- Train-category

Better parts



- MEYLE-HD flex discs are technically superior to OE with 4 years guarantee and in many cases first-to-market

Better solutions



- MEYLE-KITS save time and money in the daily workshop business in drive train product groups „wheel bearings“, „drive shaft support“, and „automatic transmission oil change kits“

Competitive portfolio



- **Competitive coverage rates** for European markets and European CarParcs outside Europe for **automatic transmission, „flex discs“ and „drive shaft support“**
- Continuous portfolio expansion, focused on top sellers for „C.V joint kits“, „drive shafts“, „wheel bearing hubs and kits“



With MEYLE ATM-KITs we are enabling the IAM to service automatic transmissions rather than sending business towards OE



- >60 vehicle-specific kits contain everything that is needed for a change for >5,100 applications

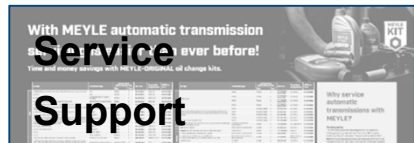

- Supporting workshops with installation videos, oil replacement tables, and by-pack instructions



- Clear matching of KITs and applications with no room for error supporting a smooth repair job



- OE-quality-level components including exclusive patented Combi-Media® and Smart-Media™-Triple filter media for 7-G Tronic (Plus) transmissions



Better performance, longer service life: Technically optimised flex disc in MEYLE- HD quality co-developed with BOGE

- **Longer service life:** Reduction of inner friction (and heat) through innovative winding technology as well as improved push and pull characteristics.
- **High-torque resistance up to 3000 Nm:** Improved thread stability for a superior breaking load. Full-surface, comprehensive loop sets inside ensure high strength.
- **Anti-aging rubber material:** The rubber blend is resistant to temperatures of up to 130°C (270°F) – Compared to competitor products that are only resistant up to 90°C.
- **4 year HD-guarantee** on all MEYLE-HD parts

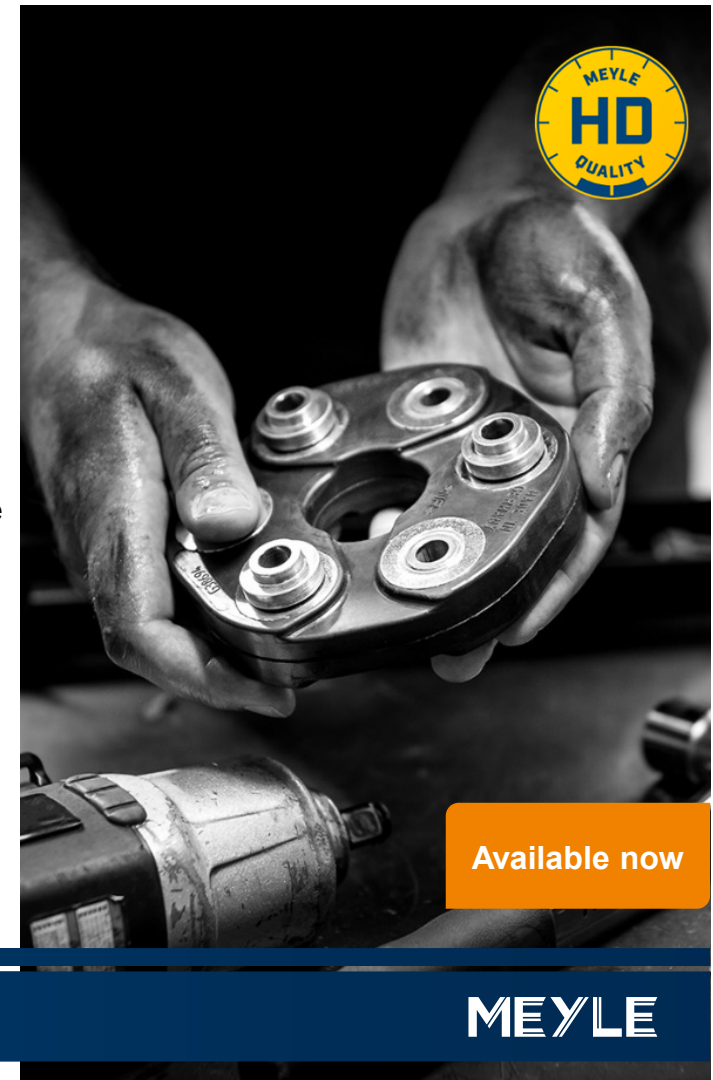

While we offer ~24.000 reliable spare parts in total, we are aiming at strategic supplier status in following (sub-) categories:

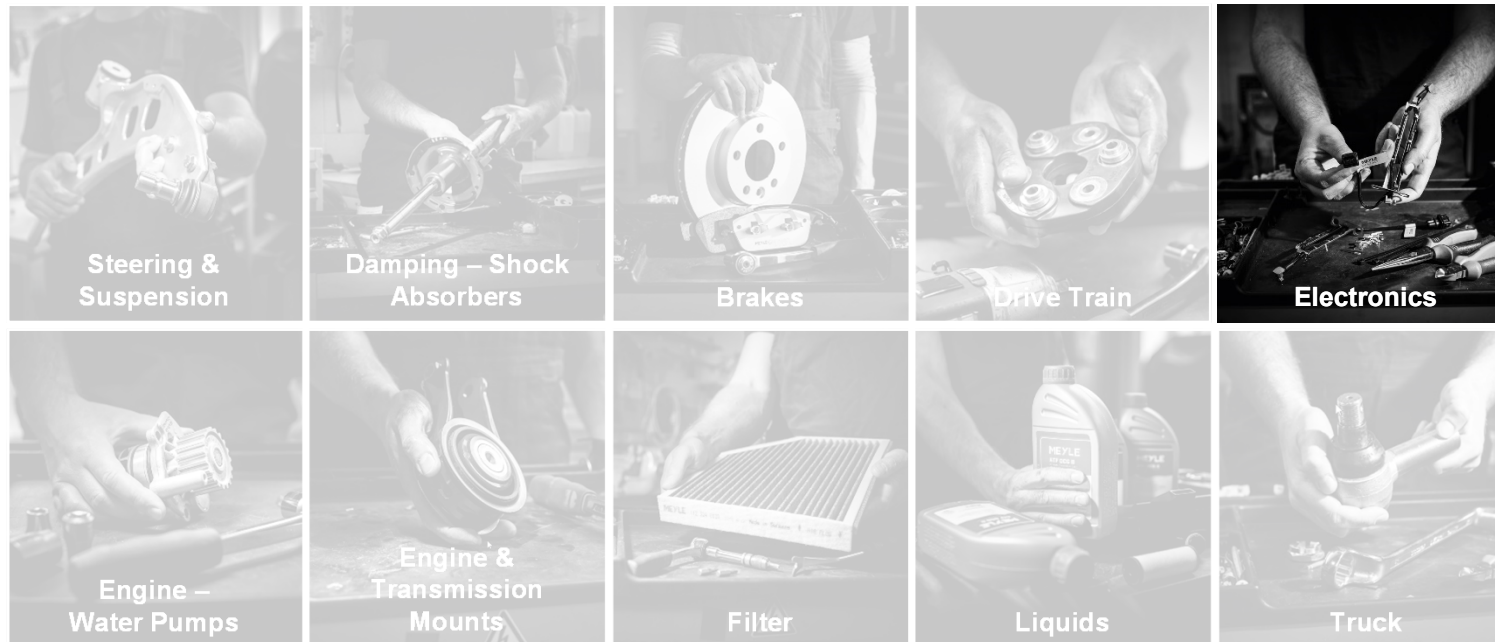

Better portfolio solutions in quality and data



- Specification true to OE, **manufacturing according to highest standards and 100% function testing**
- Engineering competence makes MEYLE a **great partner for OE- and special projects**
- Most **accurate application data guarantees fitting accuracy** for end customers and minimizes return costs
- **In-house data and quality management** centralized in Hamburg, Germany
- **Consolidation of part numbers** based on application data and technical specifications for **optimized inventory management of our customers**
- **Competitive coverage rates** for European markets and European CarParcs outside Europe
- Range and Portfolio extensions according to **market needs, developments, and future trends**
- Unique IAM electronics solutions: **MEYLE-ABS-Sensor-Kits**



Our electronics portfolio continuously extends according to market needs, developments, and future trends

Measures and measures and measures...accurately every time



Exhaust gas system

- Exhaust gas temperature sensors
- Exhaust pressure sensors
- Oxygen Sensors



Engine management

- Camshaft sensors
- Crankshaft sensors
- Coolant temperature sensors
- Throttle Position Sensors
- Knock Sensors
- ...



Assistance and safety system

- ABS sensors
- ABS-Sensor-KIT

Gets you started under every condition



Ignition parts

- Ignition coils
- Glow plugs
- Glow plug control units

High pressure for the perfect flow



Pumps

- Fuel pumps
- Wash water pumps

Safety and comfort



Switches

- Brake light switches
- Steering column switches
- Ignition switches
- Headlight switches
- Window lifter switches

Product Portfolio: Focus Category Electronics

MEYLE

Bold = MEYLE Focus Product

While we offer ~24.000 reliable spare parts in total, we are aiming at strategic supplier status in following (sub-) categories:

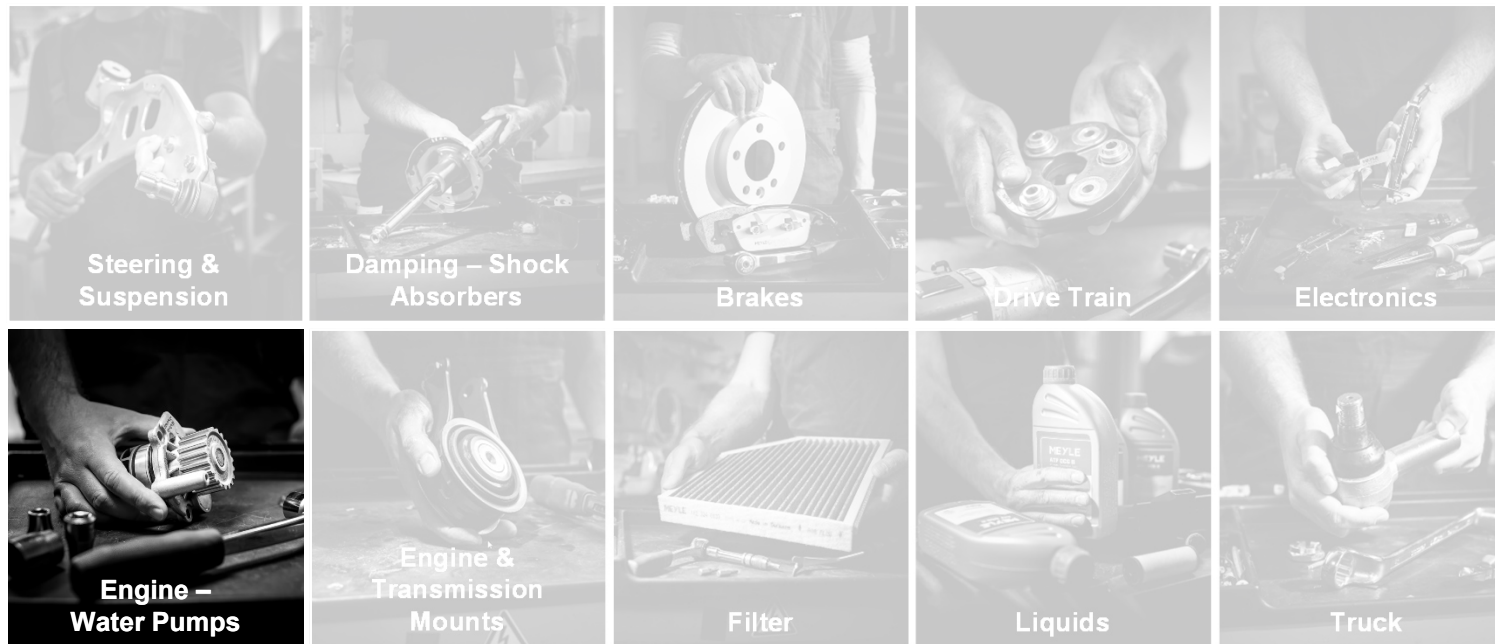

With leading coverage rates in Europe for European and Asian makes, MEYLE is in the position to be a primary supplier for water pumps

Quality standard

- Our **quality** department operates **according to the highest standards in the IAM: Our own!**
- MEYLE engineers and QM department perform extensive testing on all water pump production samples before release

Better parts

- **MEYLE-HD water pumps** last longer than OE due to the hard wearing SiC/SiC mechanical seal from KACO and a European bearing
- MEYLE-HD water pumps are **made in Germany**

Better solutions

- With all the necessary components for a smart repair of the timing belt drive system including the water pump, **MEYLE-ORIGINAL water pump kits save time and effort**

Leading coverage rates

- **Leading coverage rates for European markets as well as European CarParcs outside Europe**
- Coverage in select markets > 90%; 89% of the EU registered car park



MEYLE-HD water pumps are designed for a longer life



Water pump bearing: OE quality, according to application:

- Equipped with 4-point ball roller bearings: Better distribution of high radial forces & increased axial support
- Or:
- Equipped with angular contact ball bearings: Absorption of axial and medium radial forces as well as increased axial support

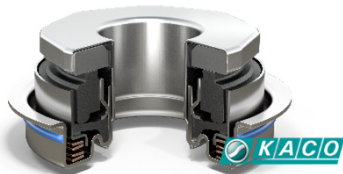

KACO SiC/SiC mechanical seal

- Extreme hard wearing SiC/SiC mechanical seal: Resistant against abrasive contamination
- Housing made of stainless steel, resistant to high temperature



MEYLE-HD guarantee:

- Lasts longer than OE
- MEYLE provides a 100,000-mile guarantee for all MEYLE water pumps and a 4-year warranty for MEYLE-HD water pumps*

While we offer ~24.000 reliable spare parts in total, we are aiming at strategic supplier status in following (sub-) categories:

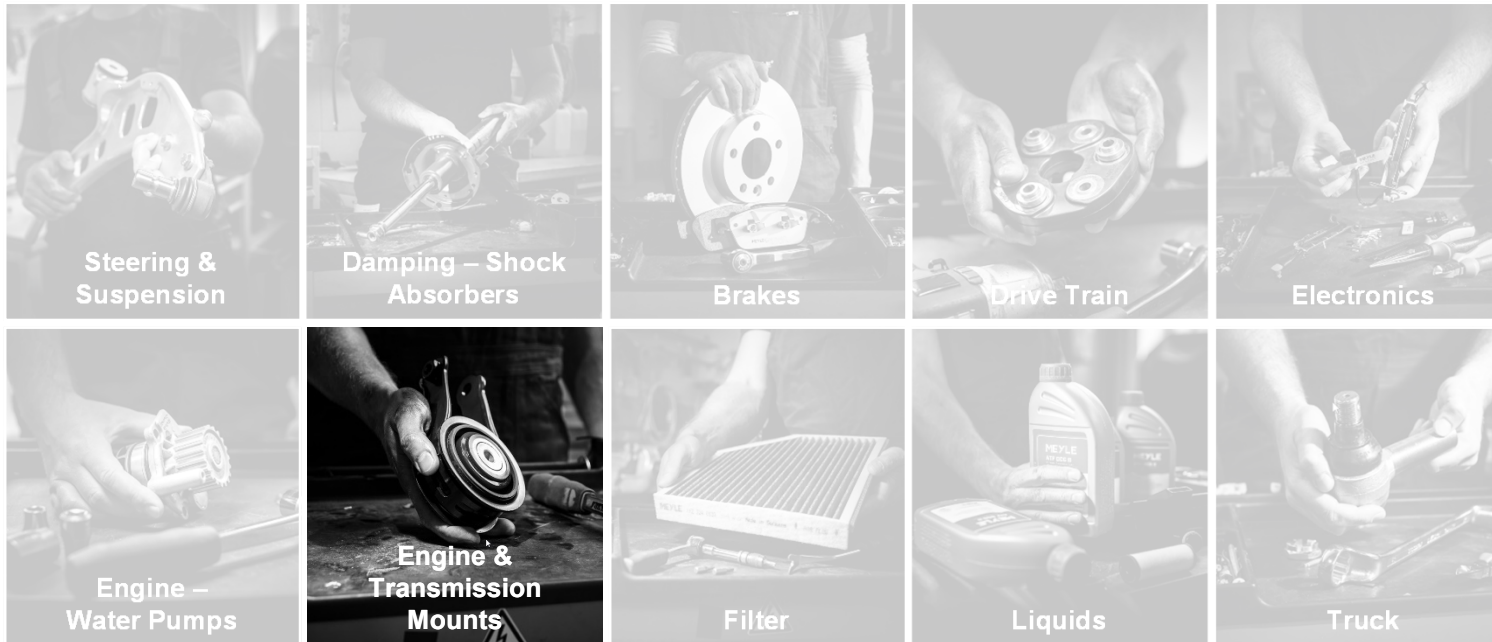

NVH: noise, vibration and harshness – engine and transmission mounts

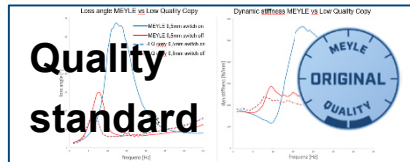

- Specification true to OE, **manufactured according to MEYLE standards**, meeting and exceeding international production IATF 16949



- **Competitive coverage rates** for European markets and European CarParcs outside Europe
- Continuous expansion of portfolio



- MEYLE-HD engine mounts are **technically superior to OE**, combining durability with comfort and supported with 4 years guarantee



While we offer ~24.000 reliable spare parts in total, we are aiming at strategic supplier status in following (sub-) categories:



With more than 1,400 Filter solutions, true to the Original and even more performant, we are a high quality extension-supplier

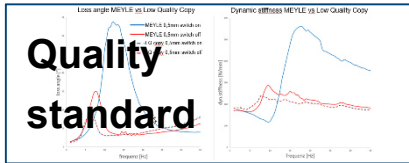

High quality in all 4 product sub-categories: Oil, Air, Fuel, and Cabin Air filters:

- supplier factory auditing
- development through OE sampling
- Testing by both supplier and our own Q-Lab
- Goods-in control on all shipments

MEYLE-PD cabin air filters **reduce fine dust and NOx**:
Designed for cleaner air inside and outside the car!

- **Competitive coverage rates for European markets as well as European CarParcs outside Europe**
- Coverage in select markets > 90%; cabin air filters at 86% across EU

MEYLE **brand promise throughout the category**:
MEYLE marking and packaging on all parts including batch and production data for a unified image

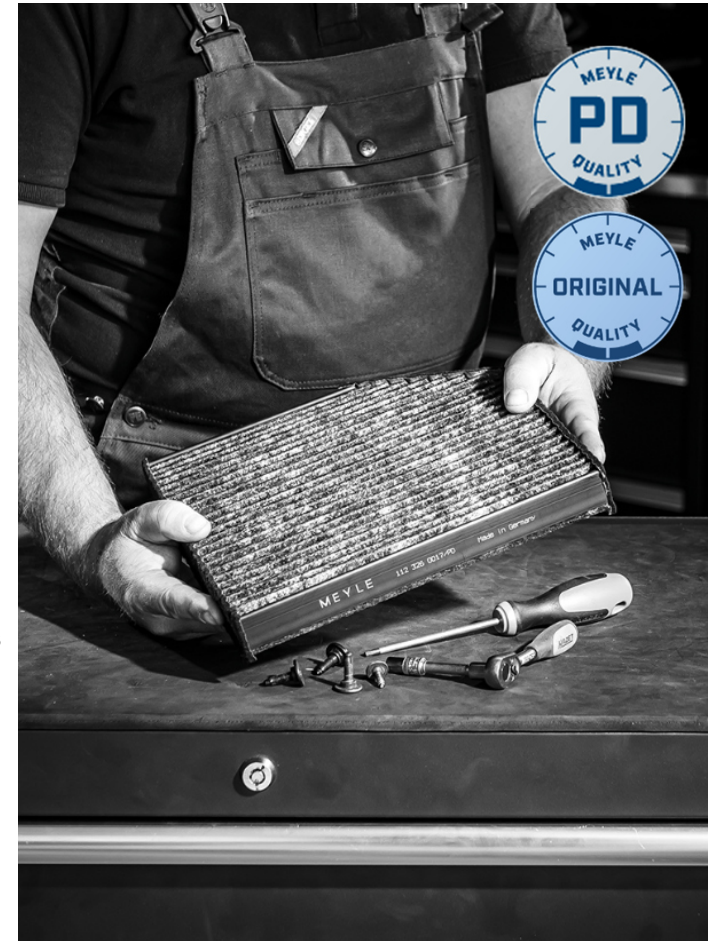

In the „cabin air filter“ sub-category, MEYLE offers four specifications to address different target groups

- Growing awareness for clean cabin air make ~400 MEYLE-Original cabin air filters a fast growing category
- 38 PD-Filter set a new IAM reference for clean in-car air



Commuters and professional drivers	Allrounder against mould, bacteria and smog	„City- and short distance drivers“	„NO worries about air-quality-drivers“

Filter Function	PD cabin air	Biofunctional active carbon	Active carbon	Particle
Filters pollen, dirt particles, dust	✓	✓	✓	✓
Filters fine dust and soot	✓	✓	✓	✓
Binds gases such as ozone, nitrogen and sulphur dioxide	✓	✓	✓	
Reduces odours by binding gases	✓	✓	✓	
Protects against micro organisms, bacteria and moulds fungus		✓		
Enhanced separation of fine dust	✓			
Enhanced absorption of NOx	✓			

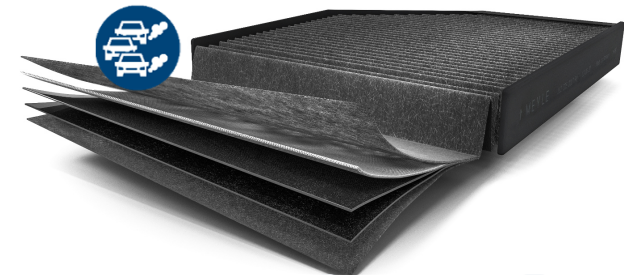

Ultra clean cabin air



Improved air flow



Permanent Nox reduction

While we offer ~24.000 reliable spare parts in total, we are aiming at strategic supplier status in following (sub-) categories:

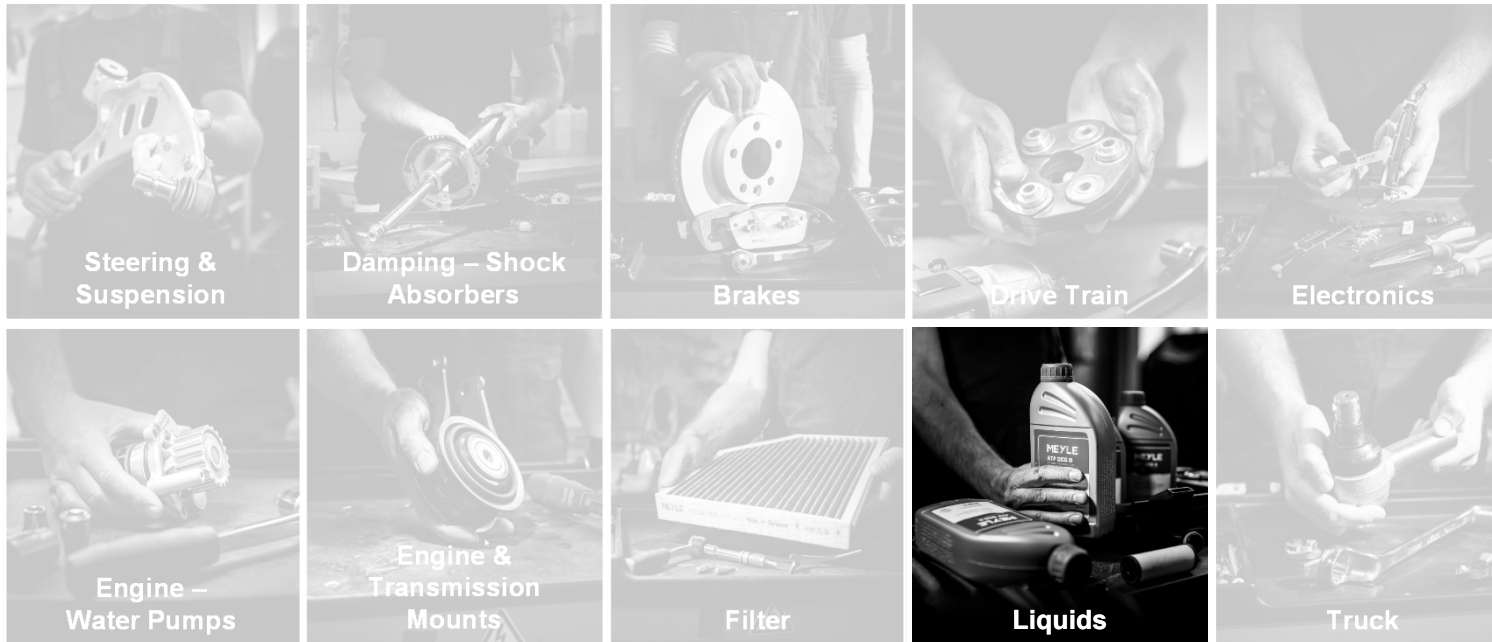

MEYLE offers transmission fluid, engine oil, antifreeze, and brake fluids according to car manufacturers' specifications and consistently „Made in Germany“

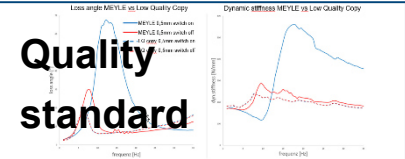

- All MEYLE liquids „Made in Germany“ by trusted suppliers according to MEYLE standards



- **Car application at first sight** on the front of the bottle
- Stable design of 1,5 Ltr. bottles: **Clean pouring without spilling**
- **Integrated measurement unit** on side of bottle*
- **Booklet with safety instructions** in 17 - 22 languages attached*



*as applicable

While we offer ~24.000 reliable spare parts in total, we are aiming at strategic supplier status in following (sub-) categories:

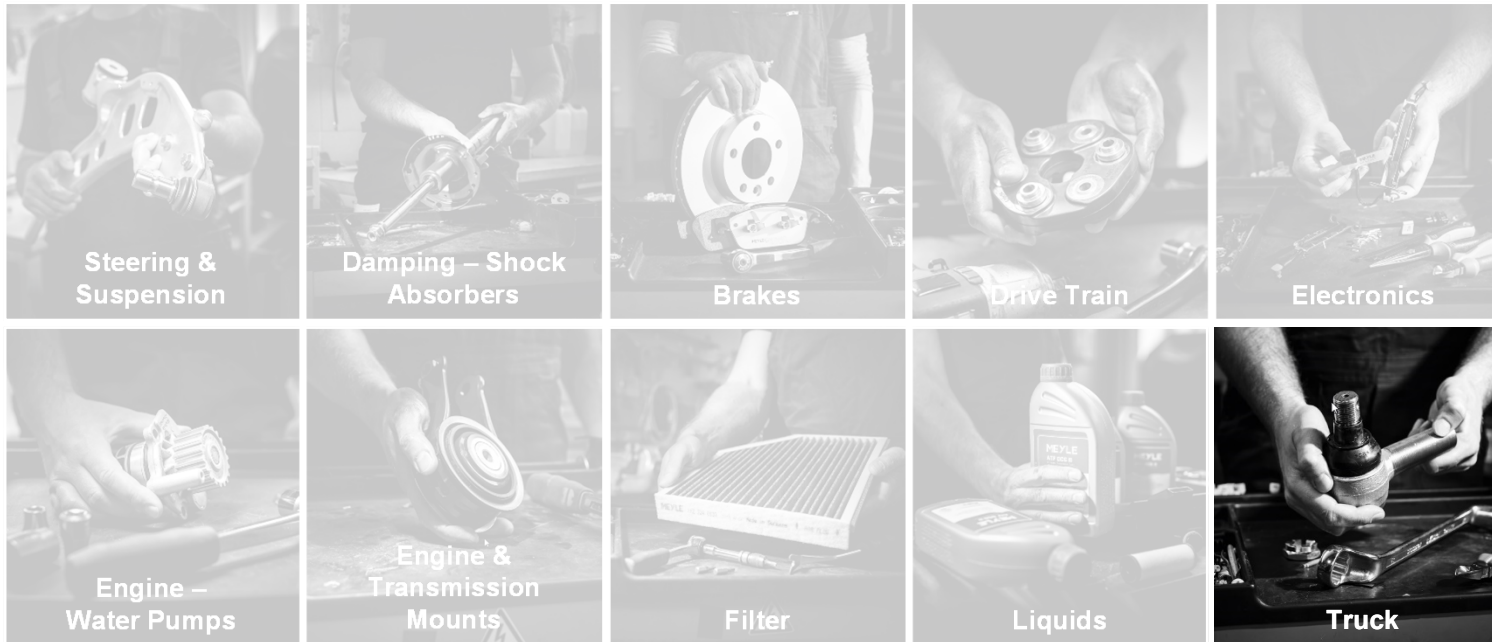

MEYLE Truck is your first choice for better parts and solutions to keep trucks rolling



Manufacturing competence

- Manufacturer with **25 years of engineering know-how**, always striving for better parts and solutions
- Tested by the strongest: We are engineering, **developing and testing in collaboration with FIA ETRC Truck Sport teams**



Better parts

- **MEYLE-HD products in steering are technically superior to OE**
- **MEYLE-PD brake pads provide longer service life**



Better solutions

- **MEYLE-KITS** such as „ribbed belt kits“ **save time and money**



Better data

- **Highest data quality** due to regular research and update of our product portfolio according to OEM information



Our Truck focus models



Mercedes Benz

- Actros MP4
- Antos
- Atego 3
- Arocs



MAN

- TGX
- TGS
- TGM
- TGL
- TGA



DAF

- XF
- CF
- LF



Volvo

- FH 3 + 4
- FM 3 + 4
- FL 3
- FE 3



Scania

- P,G,R,T
- L,P,G,R,S



Iveco

- Stralis XP
- Stralis NP
- Stralis Hi-Way
- Eurocargo 3 / 4



Renault Truck

- T-Serie
- C-Serie
- K-Serie
- D-Serie



Our Truck focus parts



Cooling system

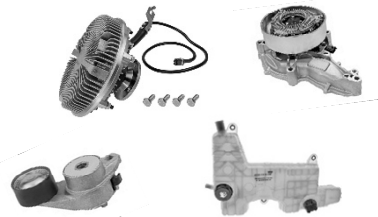

- Water pumps
- Expansion tanks
- Belt tensioniers
- Fan Clutches
- Expansion tank caps
- Tension rollers, ribbed belts
- V-ribbed belts
- Radiator fan motors

Steering and suspension



- Tie rods and tie rod ends
- Stabiliser links
- Control arms
- Rods/struts, suspension
- Drag links
- Hydraulic pumps, P/S

Sensors and switches



- Sensors:
 - NOx
 - compressed-air system
 - exhaust gas temperature
 - exhaust pressure
 - ABS wheel sensors
 - coolant level and coolant temperature
 - Boost pressure and fuel pressure
 - oil pressure
 - Temperature pressure

To ensure our quality, we are working together with truck race team “SL Trucksport 30” to test our parts under the toughest conditions

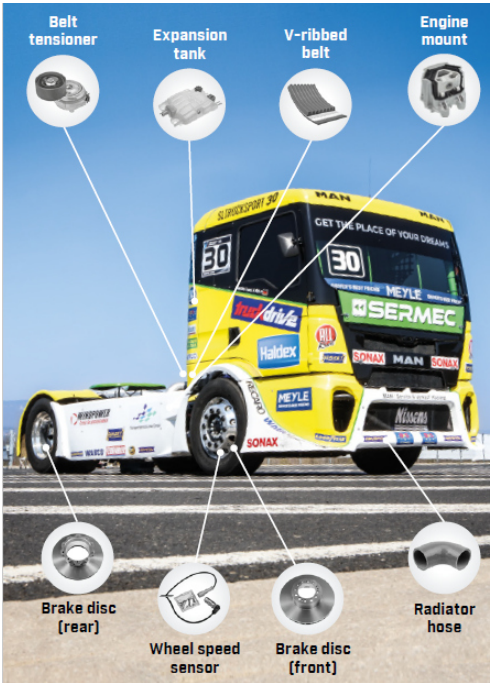
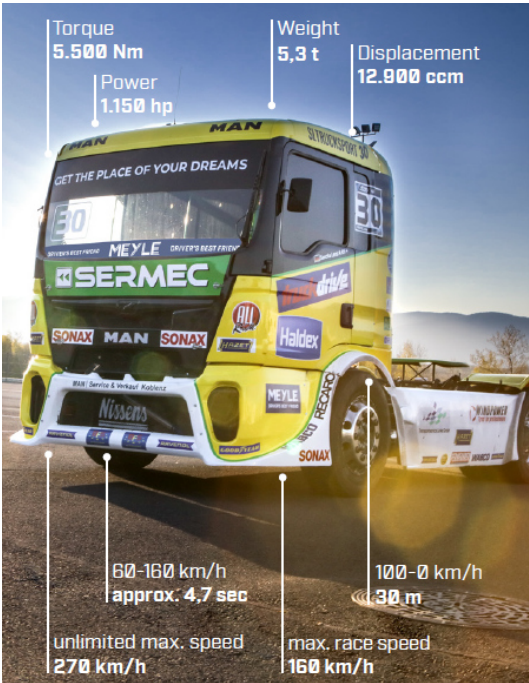

“MEYLE is known for the better parts. And I can confirm this without exception. Through high-quality parts, we were able to score points during the races and secure top positions – also thanks to MEYLE!,,

Sascha Lenz, pilot of SL TruckSport 30

In Summary, as reliable as a friend, MEYLE supports the independent automotive aftermarket with better parts and solutions

- We **manufacture in the best factories in the IAM around the world** according to the highest standards in EVERY category we serve: our own
- We **strengthen our brand with friends and partners** with a common ambition: to be the premier automotive aftermarket brand
- We are working towards **becoming the most reliable partner** in the aftersales market: will you come with us?



DRIVER'S BEST FRIEND





MEYLE