

VICTOR REINZ®



FOR A BETTER INSIGHT!
PRACTICAL TIPS FOR THE WORKSHOP

Tips and Practical Information

Expert Knowledge for every aspect of Engine Sealing





VICTOR REINZ – Just seal it!

As an original equipment manufacturer and replacement part supplier, Dana delivers innovative sealing technologies of the highest quality under the brand name Victor Reinz®. All spare parts in the comprehensive product range meet the high standards of OEM quality.

Almost all known brands and models of automobile manufacturers worldwide are equipped with professional sealings solutions from Dana in the areas of engine and exhaust. The company be-

longs to the top suppliers of the large buying groups in terms of availability and supply.

Dana's partners can rely on getting the best service. That includes not only individual advice, but also fast delivery of the desired parts. Highly dedicated employees fulfill the customer's needs with great innovative power, concentrated expertise, and, above all, constant passion.

The Dana Holding Corporation, headquartered in the USA, is the world's leading provider of axles, shaft drives, off-highway transmissions, sealing and thermal management products, and original replacement parts. Under the name Power Technologies Group, the group pools its competencies in the area of sealing technology. Dana currently has around 23,000 employees on five continents worldwide.

Content

- 4 **Multi-layer Steel (MLS) Cylinder-head Gaskets and Component Surfaces**
Tips and Practical Information No. 1
- 10 **Cylinder-head Bolts and Cylinder-head Installation**
Tips and Practical Information No. 2
- 16 **Composite Cylinder-head Gaskets and Damage Analysis**
Tips and Practical Information No. 3
- 22 **PTFE Oil Seals and Their Installation**
Tips and Practical Information No. 4
- 28 **MLS Cylinder-head Gaskets and Damage Analysis**
Tips and Practical Information No. 5
- 34 **Sealants and Sealant Remover**



Multi-layer Steel (MLS) Cylinder-head Gaskets and Component Surfaces

Tips and Practical Information No. 1

Multi-layer Steel (MLS) Cylinder-head Gaskets – Innovative Sealing Systems for New Engine Concepts

Trend-setting Developments

Improved torque and performance, better fuel economy, reduced emissions. During engine design, the development targets determine the demands placed on modern sealing systems. Increasingly high ignition pressures and temperatures lead to high stresses for head gaskets. The solution: Multi-layer steel cylinder-head gaskets – or simply MLS head gaskets.

By 1992 Dana had already developed and launched the first series-produced MLS head gaskets. Today, these gaskets are state-of-the-art, and enable development engineers worldwide to implement innovative new engine concepts.

Multi-layer Steel Offers Higher Sealing Potential

MLS head gaskets consist of two to five sheets of spring or carbon steel, which are sandwiched with the sealing material to form multi-layer steel head gaskets.

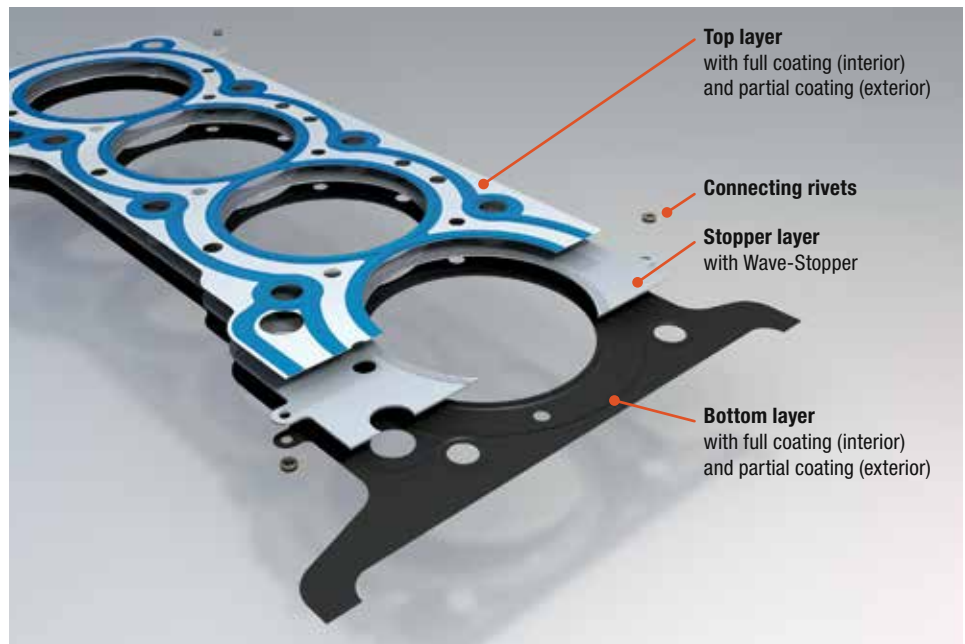

For improved sealing of gases and liquids, beads around combustion chambers and oil/coolant passages increase the local sealing pressure (macro sealing), whilst full-surface or partial elastomer coatings provide additional sealing tightness (micro sealing).

▲ *Typical 3-layer MLS head gasket with top sheet, active layer with Wave-Stopper, and bottom sheet beads plus full-surface (interior) and partial (exterior) elastomer coatings improve the sealing potential of these modern sealing systems. Beads for macro sealing, and elastomer coating for micro sealing.*

Optimum Surface Finish for Better Sealing

Properties of Sealing Surfaces

Also in future, MLS head gaskets will represent the leading sealing concept. Already today, sealing between cylinder head and engine block is achieved almost exclusively by means of multi-layer steel head gaskets. However, it is not only the head gasket's quality that is responsible for perfect sealing. An equally important role is played by the surface qualities of cylinder head and engine block.

The demands placed on the surface finish are a decisive factor for reliable sealing results. Therefore, it is essential that the specified values are observed when installing head gaskets. Hereby, there is no difference between composite gaskets and MLS gaskets.

Surface Deviations

The following surface deviations lead to reduced surface qualities of cylinder head and engine block:

- Component unevenness
- Component distortion
- Waviness (deviations in parallelism)
- Roughnesses (grooves and scores)

Component Unevennesses and Distortions

Component unevenness and distortion can be determined by means of a straightedge. Measurements are made using the light-gap method. The edge of the test device is placed on the surface, and moved over the bolt holes longitudinally and transversely. Hereby, any unevennesses are made visible by the light gap.

For passenger cars the measurement results over a longitudinal length of 100 mm must be less than 0.03 mm, and less than 0.05 mm over a length of 400 mm, whilst in the transverse direction they must be less than 0.03 mm over a length of 100 mm.

For commercial vehicles the measurement results over a longitudinal length of 100 mm must be less than 0.03 mm, and less than 0.10 mm over a length of 1,000 mm, whilst in the transverse direction they must be less than 0.03 mm over a length of 100 mm.

The standards for the surface texture are defined in DIN EN ISO 4287. The corresponding values are $R_z \leq 15 \mu\text{m}$ for roughness, and $P_t \leq 22 \mu\text{m}$ for profile depth. Consequently, cylinder head gaskets must provide comprehensive macro and micro sealing properties.

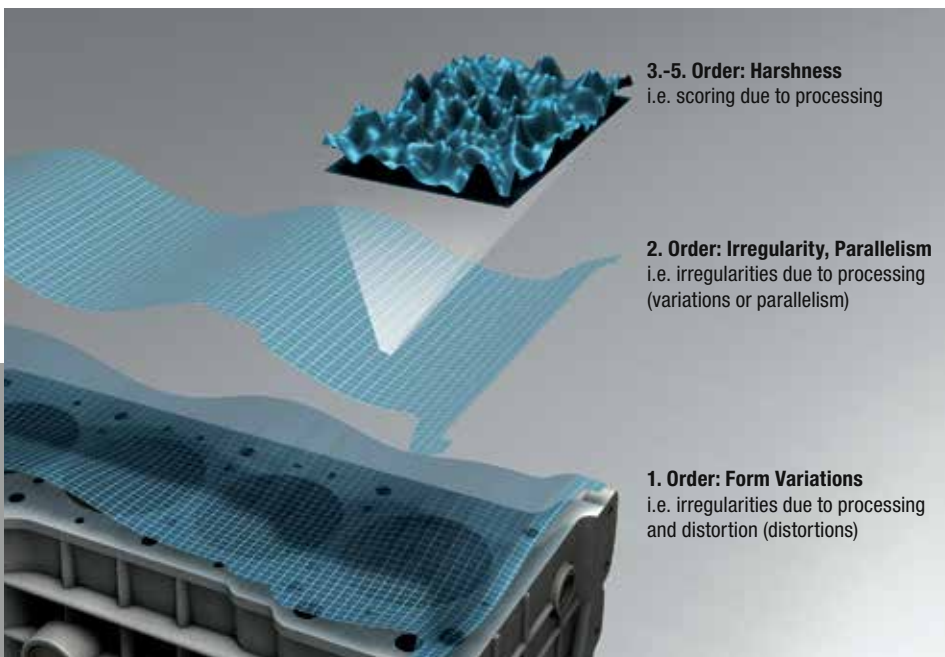

◀ *Example of influences of surface quality due to surface deviations on an engine block.*

Waviness and Roughness

Waviness and roughness are measured with the help of a sensing probe that is moved horizontally over the sealing surface. At a wave spacing greater than 8 mm waviness should be less than 10 μm . Roughness R_z must not be greater than 15 μm .

Amongst other results, evaluation of the recorded data gives the maximum roughness depth R_{max} . This is an important value for surface quality, as it indicates the largest possible leakage channel.

Practical Experience

In a large-scale test on 1,200 engine blocks with eight measurements per block, the measured values for R_{max} were between 8 μm and 18 μm . Only very few surfaces exhibited R_{max} values up to 25 μm .

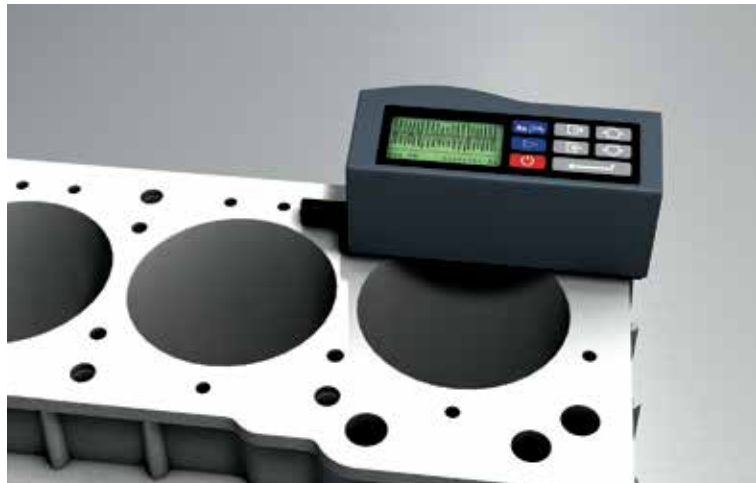

▲ *Maximum values for waviness and roughness (grooves and scores) practical measurement using a sensing probe, and indication of possible leakage channels.*

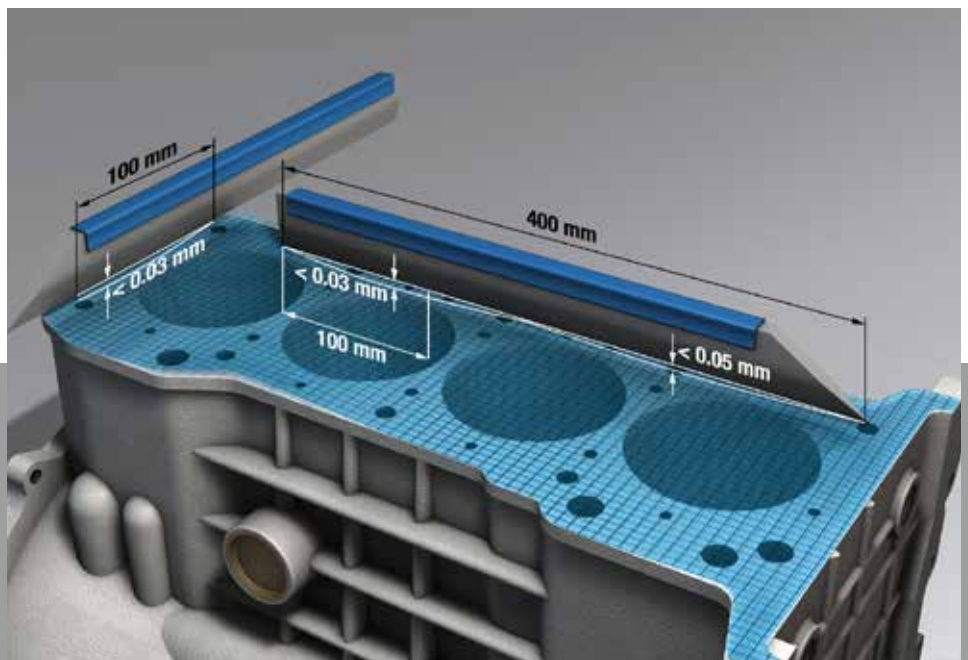

▶ *Maximum values for component unevennesses and distortions for passenger cars. Practical measurement using a straightedge and the light-gap method.*

MLS Head Gaskets – The Optimum Solution for Every Surface Quality

The special design of multi-layer steel gaskets enables them to adapt to every surface texture, provided that the surface quality lies within the specified tolerances.

TIP FROM THE EXPERTS

Be sure to observe the demands placed on surface quality:

→ **Component unevenness for passenger cars**

*less than 0.03 mm over a longitudinal distance of 100 mm;
less than 0.05 mm over a longitudinal distance of 400 mm;
less than 0.03 mm over a transverse distance of 100 mm*

→ **Component unevenness for commercial vehicles**

*less than 0.03 mm over a longitudinal distance of 100 mm;
less than 0.10 mm over a longitudinal distance of 1,000 mm;
less than 0.03 mm over a transverse distance of 100 mm*

→ **Waviness**

maximum 10 μm at wave spacing ≥ 8 mm

→ **Roughness**

*$R_z \leq 15 \mu\text{m}$
 $R_{max} \leq 20 \mu\text{m}$*

If the above values are observed, MLS gaskets provide the most reliable seals. Only if the values are exceeded, will it be necessary to re-machine the surface.

Cylinder-head Bolts

Nowadays, manufacturers make exclusive use of so-called stretch bolts (waisted bolts). Without problems, these bolts can be extended beyond their elastic limit into the plastic region.

When a certain tightening torque (pretorque) has been reached, the bolt is tightened further by a defined amount (prevailing angle or torque).

If the torque-angle tightening method is used, retorquing of the head bolts is no longer necessary.

With the torque-angle method, the head bolts are elongated plastically, i.e. permanently. After disassembly, they are clearly longer than new bolts. For safety reasons, cylinder-head bolts should therefore always be used only once.

You Can Trust the Dana Specialists

High-quality Victor Reinz MLS head gaskets compensate component unevenness and distortion perfectly by means of controlled sealing contact pressure. Macro sealing is effected by correspondingly designed beads in the sealing areas of the outer spring steel layers. Excellent micro sealing is ensured by the additional conformability provided by elastomer coatings on the outer (head and block) layers, which adapt to the waviness and roughness (grooves and scores).

Victor Reinz MLS head gaskets offer reliable sealing for engine block and cylinder head surfaces with R_{\max} values up to 25 μm .

TIP FROM THE EXPERTS

With the torque-angle tightening method, the head bolts are elongated permanently. For safety reasons, cylinder-head bolts should therefore always be used only once.

Additional data on this subject is given in our Practical Information No. 2 (Cylinder-head bolts and head installation).

MLS – Increased Performance and Reliability

MLS and composite gaskets place the same demands on surface quality. Except for the torquing method used, there are no special differences to be observed during installation. Nonetheless: The future belongs to multi-layer steel gaskets. Thanks

to the significantly higher sealing potential, higher ignition pressures with simultaneously lower bolt tensions are possible. As a leading manufacturer of MLS head gaskets, Dana is excellently prepared for present and future trends in engine construction.

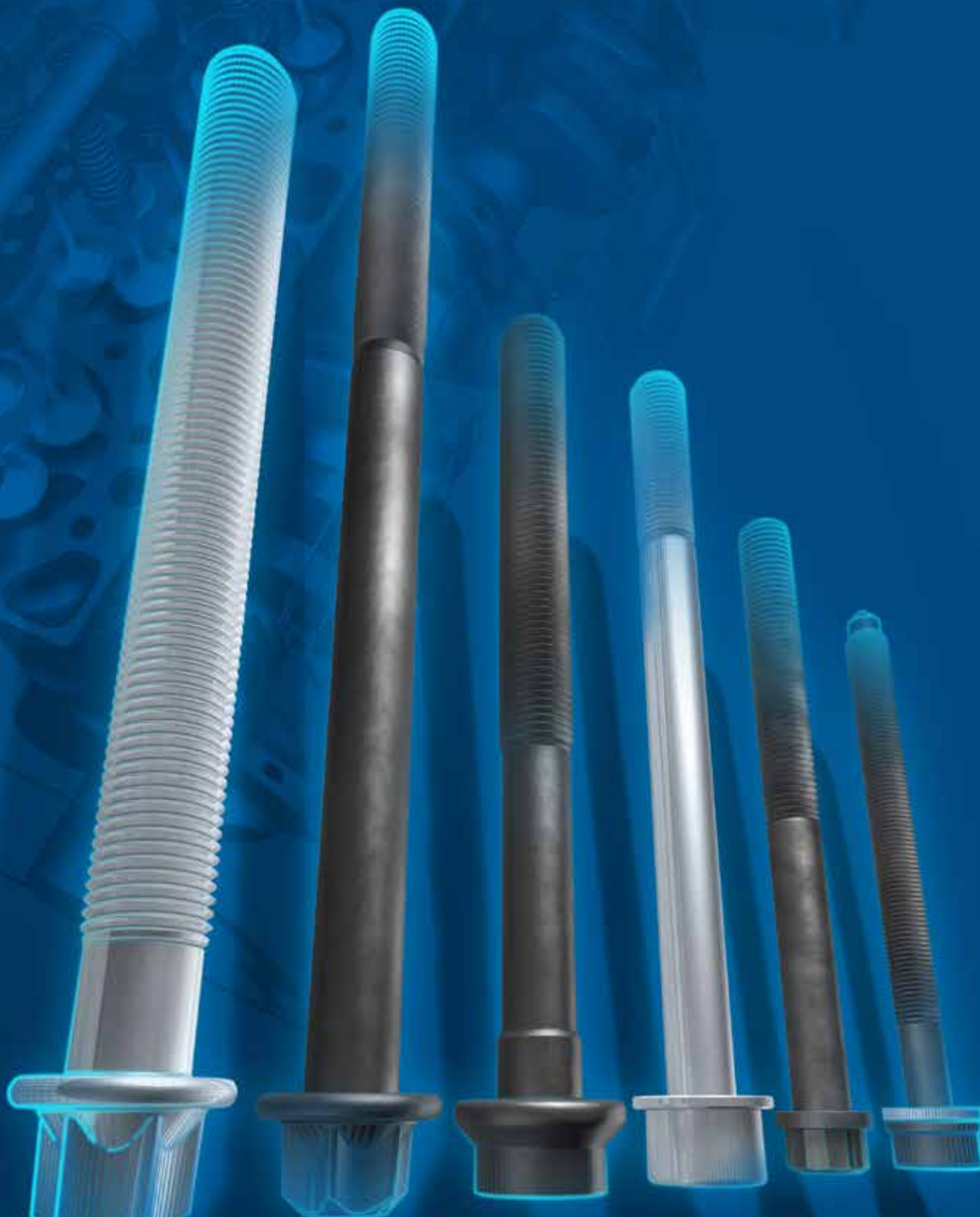

Cylinder-head Bolts and Cylinder-head Installation

Tips and Practical Information No. 2

Cylinder-head Bolts – Strong Joints for Perfect Sealing

Connecting Element

Cylinder-head bolts are the connecting elements between engine block, cylinder-head gasket, and cylinder head. The bolt tightening force is an important factor for the mutual sealing of combustion chamber, lubricant and coolant channels, and the ambient air. A task that must be performed perfectly with cold or extremely hot engines, at negative and high positive pressures.

Surface Pressure

When tightening (torquing) the cylinder-head bolts, the bolt force generates the so-called surface pressure, which is essential for achieving a perfect seal. Hereby, and in combination with the applied torquing method, the bolts have a strong effect on surface pressure quality.

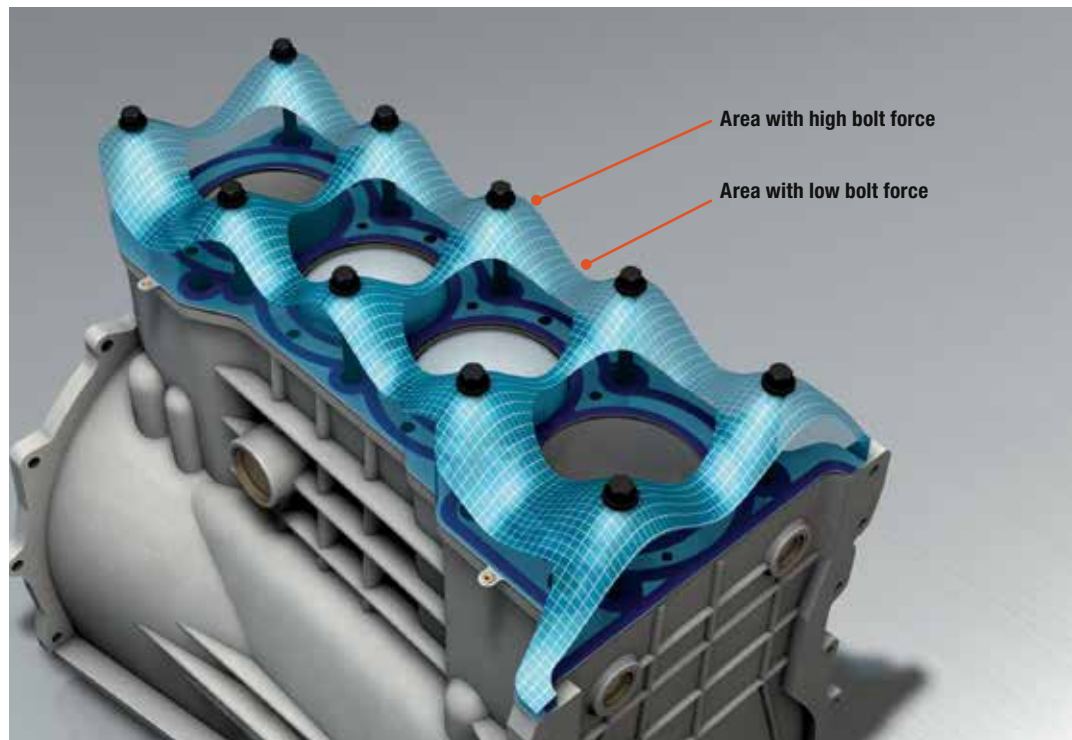

▲
When torquing the cylinder-head bolts, the bolt force generates a surface pressure, which is essential for achieving a perfect seal.

Surface pressure describes the force per unit of contact surface area between two components, e.g. between cylinder head and head gasket, or engine block and head gasket. As opposed to the clamping force, surface pressure is not constant across the entire contact area.



Special Bolts for Higher Bolt Forces

Innovative Development Needs No Retorquing

For economic reasons, engine builders developed head gaskets in the 80s that do not require retorquing. The assembly of cylinder heads without having to retorque the head bolts represented a technical innovation for series production. Similarly, when replacing a head gasket, torquing in several steps was no longer necessary.

This objective was only achievable through optimum matching of all

the components involved. A tight, compound joint of engine block, cylinder-head gasket, cylinder head, and head bolts.

Stretch Bolts

Bolts that are tightened beyond their elastic limit (yield point) into the plastic region ensure high and uniform bolt clamping forces. An important prerequisite for reliable sealed joints without retorquing. In this respect, stretch bolts offer decisive advantages over rolled shank bolts. By reducing its shaft diameter, the bolt is able to respond elastically to dynamic sealing gap movements, i.e. adaptation is greatly improved.

Torque-angle Method

In the first step, the bolt is snugged down to the cylinder head by means of a pretorque. With the second step, the so-called torque or tightening angle, the bolt is tightened into the plastic region, i.e. beyond its elastic range.

Using the torque-angle method, the variations in bolt clamping force lie in a range of $\pm 10\%$. Using the simple torquing method with several steps, the variations will be within $\pm 30\%$ of the calculated bolt clamping force. The reasons for this lie in the dispersion range of torque values and the overall coefficient of friction, i.e. the friction occurring under the bolt head and in the threads.

Stretch bolts are designed so that they can be elongated beyond their elastic limit into the plastic region without problems. When a specific tightening torque has been reached, the bolts are turned further through a defined angle, which pre-loads them into the plastic region. Consequently, no retorquing is necessary.



◀ *Advantage of stretch bolt: As opposed to a rolled shank bolt, it can be tightened beyond its elastic limit (yield point) into the plastic region – a guarantee for high and uniform bolt clamping forces.*

Safety with New Bolts

With the torque-angle method, the head bolts are elongated plastically, i.e. permanently. After disassembly, they are clearly longer than new bolts. During the engine's warm-up period, the bolt is stretched even more. This applies in particular for all-aluminium and bi-metal engines, as the two materials have different thermal expansion rates.

In the worst case, a bolt that is reused can break, or it can «bottom» in the threaded hole of the engine block and cause damage. For safety reasons, cylinder-head bolts should therefore always be used only once.

You Can Trust the Dana Specialists

Cylinder-head bolts guarantee a secure and releasable joint. However, this does not mean that the same bolt can be reused for the same application. When reassembling a cylinder head, always make sure to use new head bolts. The result will be a high sealing pressure for a reliable and tight joint.

Make sure to use head bolts exclusively from quality manufacturers. Victor Reinz cylinder-head bolts comply with all manufacturer specifications, and are matched perfectly to our head gasket sets. Of course, the torquing guidelines are always supplied.

TIP FROM THE EXPERTS

With the torque-angle tightening method, the head bolts are elongated permanently. Therefore, cylinder head bolts should only be used once for safety reasons.

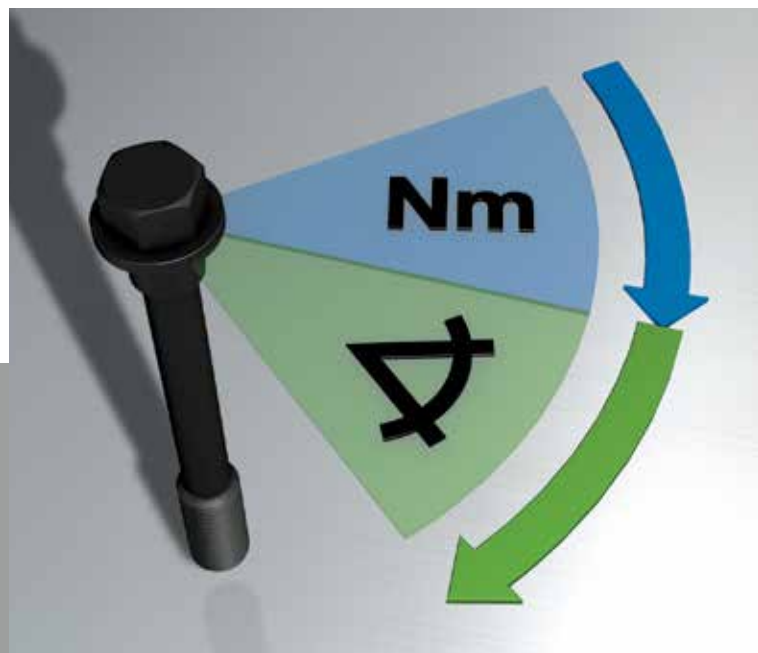

►
Torque-angle method using pre-torque and tightening angle.

Practical Tips: Preparation and Cylinder-head Installation

The first steps ...

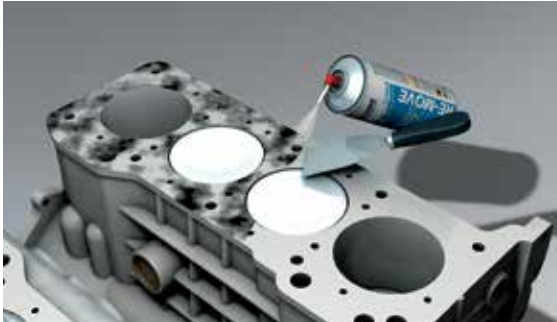

1. Carefully clean the sealing surfaces of engine block and cylinder head – dirt and gasket remnants on the surfaces are a frequent source of trouble.

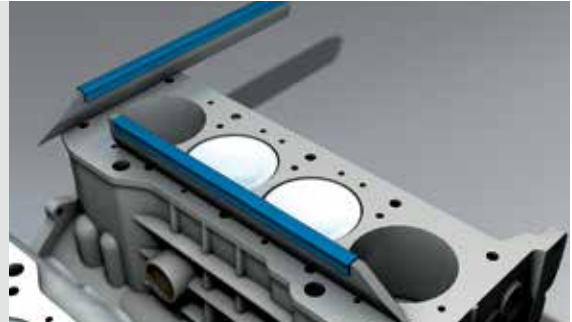

2. Use a straightedge to check the surface flatness; longitudinally and transversely.



3. Remove any gouging, component distortions, grooves or scores, e.g. by surface grinding in a specialist workshop.



4. Observe the minimum dimensions of engine block and cylinder head according to the manufacturer's specifications, as well as the specified head gasket thickness.

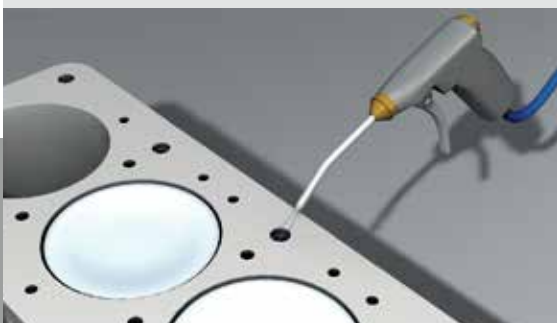

5. Clean the bolt hole threads, and remove any contamination, oil and water, e.g. with a blast of compressed air.

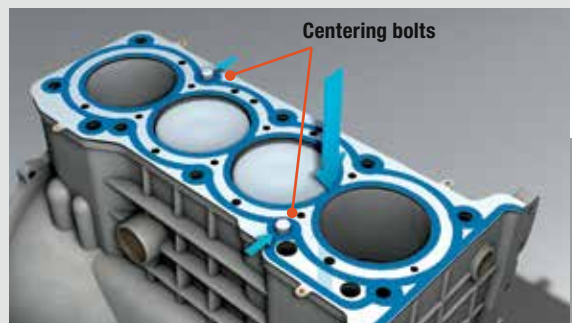

6. Position the head gasket accurately on the engine block. Do not use any additional sealing compounds, grease or oil.

Replacing the Cylinder-head Bolts

... the next steps



7. Fit the cylinder head, and take care not to damage the head gasket during assembly.



8. Always use new head bolts.

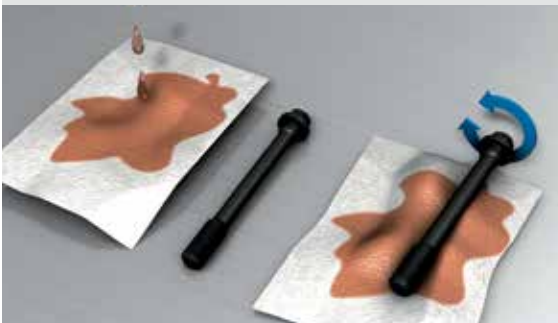

9. Lightly lubricate the bolt thread and the bottom of the bolt head by applying a small quantity of oil to a rag and rotating the bolt in the oily rag.



10. If the manufacturer specifies the use of a washer, lightly lubricate both sides.



11. Always follow the manufacturer's instructions regarding the tightening sequence for the head bolts – the instructions are not only different according to manufacturer, but can also vary depending on engine type.



12. Only use approved and recommended anti-freeze agents and corrosion inhibitors.



Composite Cylinder-head Gaskets and Damage Analysis

Tips and Practical Information No. 3

Composite Cylinder-head Gaskets – The Classical Approach to Cylinder-head Sealing

Composite Cylinder-head Gaskets

The classical composite head gasket is a compressible flat gasket. It consists of a tanged metal carrier sheet, onto which the composite material is rolled on both sides, i.e. engine block and cylinder head. Metal beads (fire rings) seal the combustion chamber and protect the sensitive composite material from overheating. The material surface is impregnated to prevent the gasket swelling when it comes in contact with liquid media such as oil, water, or antifreeze. So-called Viton elements of elastomer materials permit a partial increase of mounting surface pressure in the vicinity of oil pressure channels.

Due to the mounting surface pressure, the material is deformed slightly so that it adapts optimally to the sealing surfaces. Gaskets with low elastic recovery properties require very high bolt clamping forces for good sealing. Hereby, the minimum web width is approx. 6 mm to withstand the elevated pressures and temperatures during combustion.

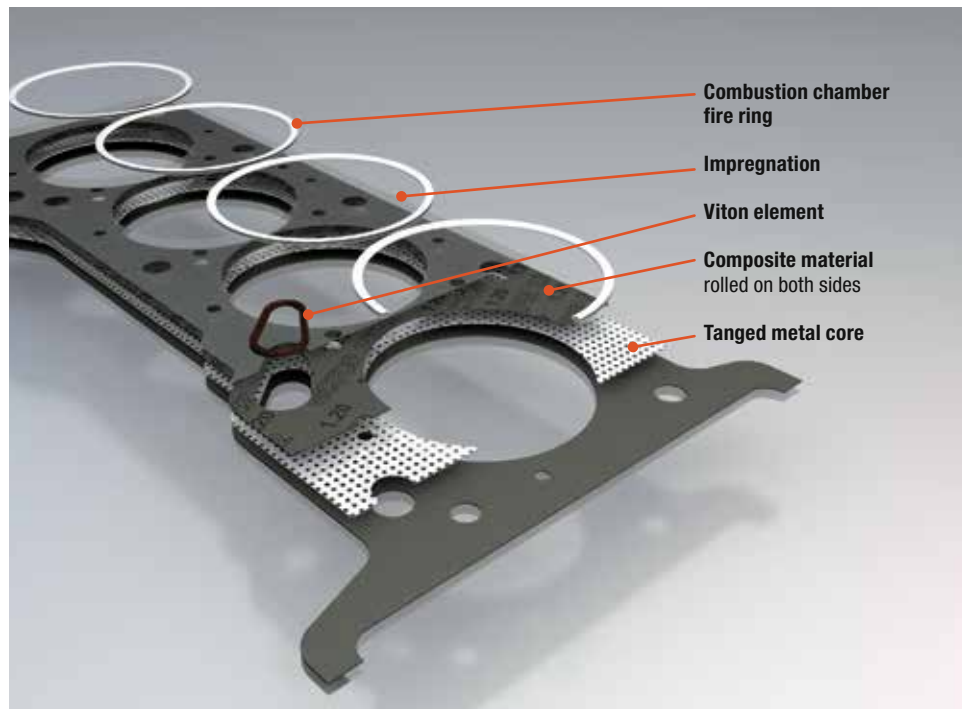

Increased Demands Due to Higher Performance

Cylinder-head gaskets must provide a gastight seal for the combustion chambers whilst simultaneously preventing leakage from the coolant and engine oil channels. In this respect, modern engines place increasingly high demands on the performance of the installed cylinder-head gasket.



Classical composite head gasket with tanged metal carrier sheet, composite material rolled onto both sides, impregnation, fire rings, and Viton element.

Overview of the demands on cylinder-head gaskets:

- Secure and lasting macro and micro sealing
- Media resistance against gas, oil, water, and anti-freeze agents
- Resistance to temperature differences and high combustion pressures
- Strength to compensate for component distortions
- Shear and tensile strength in the web area
- Transfer of bolt clamping forces
- Heat flow in the sealing gap



Damage to Composite Cylinder-head Gaskets

Different Types of Leakage

Composite head gaskets are subjected to a comprehensive testing sequence. Hereby, approval for installation is only given to top-quality and absolutely perfect head gaskets. Nonetheless, leaks can still occur during practical operation, but only in exceptional cases is this due to a faulty head gasket. There are numerous possible causes for damage to composite cylinder-head gaskets.

Gas, Oil, and Coolant Leaks

In professional terminology, leaks between cylinder head, head gasket, and engine block all fall under the general term «leakage». Hereby, a distinction is made between gas, oil, and coolant leakage, also known as «media leakage».

In total, seven different types of media leakage can occur with composite head gaskets:

- 1 Gas leakage between combustion chambers
- 2 Gas leakage from combustion chamber to coolant circuit
- 3 Gas leakage to the environment
- 4 Oil leakage to the coolant circuit
- 5 Oil leakage to the environment
- 6 Water leakage to the lubricant circuit
- 7 Water leakage to the environment

Our Tip: Analyze First, Then Repair

A faulty head gasket should be replaced as soon as possible. Gas leakages can lead to total gasket failure in a very short time,

with serious consequential damage. Often, oil and coolant leakages are not noticed in their early stages or even remain undetected. This type of damage must not be underestimated, and the head gasket should be replaced soon. Remember: A single drop of oil contaminates up to 1,000 liters of drinking water!

But don't limit yourself to a simple replacement of the head gasket. Analyze the nature of the damage first, and determine its cause. There can be many reasons for the leakage, and simply fitting a new head gasket does not automatically remove the cause.

 Leakage describes a permeable point in a sealing system, through which gases or liquids can escape or enter. Leakage can cause the entire sealing system to fail.

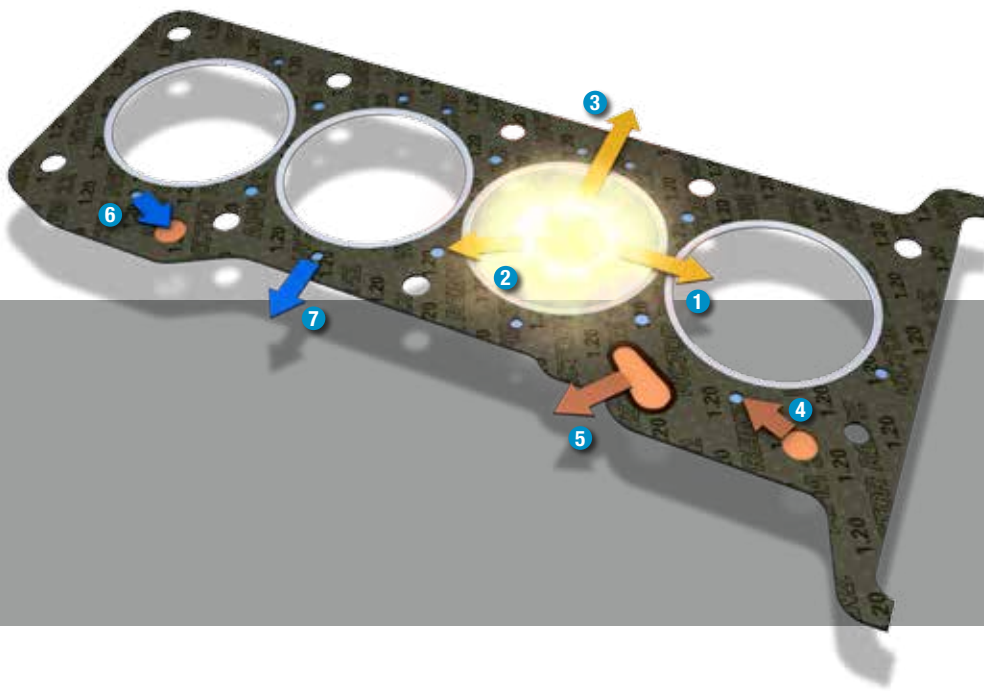

◀ Typical media leakages with composite cylinder-head gaskets.

Damage, Analysis, and Causal Investigation

Blackening

The most common type of damage to composite head gaskets involves gas leakage with blackening of the fire ring, which is relatively easy to detect on a disassembled gasket. Slight blackening at this location due to thermal loading and micro leaks is normal. However, local blackening can be an indicator for real gas leakage, which will ultimately result in destruction of the fire ring due to blowby of hot combustion gases. In this case, the gasket material under the fire ring bead loses its elastic properties due to the high thermal loading. The result is leakage.

Gas leakage with blackening can be the result of insufficient sealing surface pressure or an overheated engine. Possible causes for insufficient sealing surface pressure are faulty or reused cylinder-head bolts,



▲ Gas leakage with local blackening of the fire ring bead.

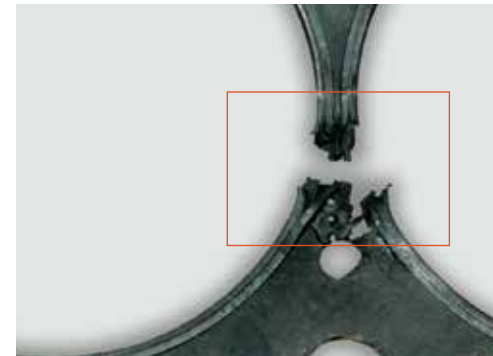

▲ Destruction in the web area due to combustion gas blowby.

incorrect torque values, damaged cylinder head and/or engine block, or non-observance of assembly instructions.

Engine overheating can be due to faults in the water pump, radiator, thermostat or hoses, insufficient coolant, or incorrect venting of the coolant system after work on the cylinder head. Other causes

for possible overheating are irregular combustion in the engine due to coke deposits, and high exhaust gas pressure in the case of catalytic converter failure.



When removing the head gasket, it is important to observe the manufacturer's instructions, in order to prevent distortions of cylinder head and/or engine block. Make sure that the component sealing surfaces are not damaged during removal of the cylinder-head gasket.

Further detailed information on the topics of cylinder head installation, head bolts, and component surfaces are given in our Practical Information No. 1 «Multi-layer steel (MLS) cylinder-head gaskets and component surfaces», and No. 2 «Cylinder-head bolts and cylinder head installation».

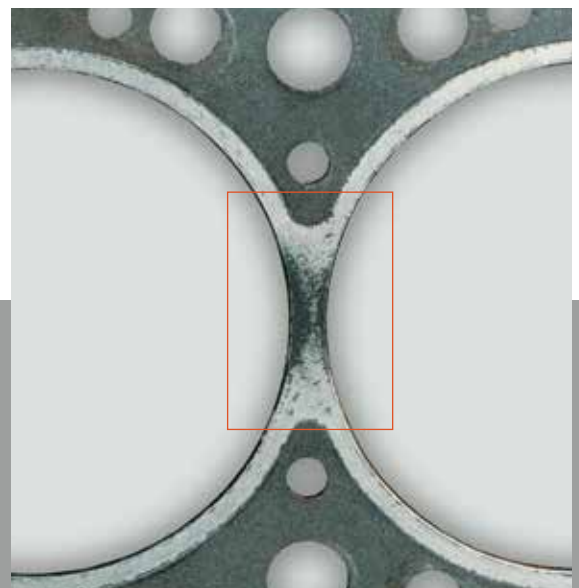

▶ Gas leakage with severe marking due to blowby of hot combustion gases.



▲ Swelling of composite cylinder-head gaskets due to overheating with steam generation.



▲ Indentation and crushing due to pre-ignition – with and without blowby.



▲ Gasket damage due to dirt and foreign objects.

Swelling

Similarly, engine overheating with simultaneous steam generation will cause damage to composite head gaskets. This kind of damage is indicated by severe swelling in the areas where the composite gasket material is exposed to the coolant in the water channels. The swelling results from the destruction of the gasket material's silicone impregnating agent, which is not resistant to steam.

Indentation and Crushing

Defective composite head gaskets that exhibit indented or crushed fire ring beads have been damaged by «pinging» (pre-ignition). During this process, uncontrolled combustion causes sharp pressure increases and extremely high combustion chamber pressures. The causes for preignition are unsuitable fuels with insufficient octane rating, wrong spark plugs, incorrect ignition timing, or excessively low engine speeds over a longer period.

Oil and Coolant Leakage

As opposed to gas leakage, gasket damage due to oil or coolant leakage is very difficult to detect on a composite head gasket after disassembly. Traces of rust and antifreeze agent with white, lime-like deposits on the gasket surface can be indicators for coolant leakages. Concrete evidence for oil leakage is found very rarely.

In addition to the known causes, coolant leakage can also result from chemical additives in the coolant, or from low-quality antifreeze agents.

Dirt, Foreign Objects, and Rough Surfaces

Practice shows that reference to the importance of clean surfaces is necessary. Repeatedly, pressed-in dirt or foreign objects are the cause for damage and leakage. Therefore, the surfaces of engine block and cylinder head should be cleaned thoroughly. This applies in particular after reworking the sur-

TIP FROM THE EXPERTS

Instructions in case of a damaged gasket:

1. Before removing the head gasket, try to identify the location of the leak clearly.
2. Analyze the damage, and determine the cause – the gasket is not necessarily the source of the problem.
3. Remedy the cause of the damage to prevent subsequent problems.
4. Only then is it advisable to install a new head gasket.
5. Observe the manufacturer's installation instructions.



▲ *Roughness of engine block and cylinder-head surfaces leads to gas blowby between the combustion chambers.*



▲ *Tearing and breakage of the composite material, and damaged Viton element due to incorrect application of additional sealing compound.*

faces in case of component unevenness, distortion, waviness (deviations in parallelism), or roughness (scores and grooves).

Perfect seals with composite cylinder-head gaskets require a correspondingly high finish of the sealing surfaces. Excessive roughness of engine block and cylinder head surfaces leads to gas blowby between the combustion chambers and inevitable failure of the head gasket.

Additional Sealing Compounds

In the worst case, the use of additional sealing compounds will destroy the gasket through tearing or breakage of its composite material. In particular, this is true for the area around the Viton element because, as the engine warms up and cools down, the additional compound prevents the element expanding into the spaces provided. The results are tearing of the material or breakage of the Viton element.

You Can Trust the Dana Specialists

Victor Reinz composite cylinder-head gaskets are your guarantee for optimal sealing results. This is not only ensured by the product's quality, but also by the enclosed installation instructions. However, in the unlikely event of gasket damage, the notes given below should be observed.

TIP FROM THE EXPERTS

When installing a composite cylinder-head gasket with Viton element, make sure that the cylinder head and the head gasket are positioned accurately. Inaccurate positioning can cause the Viton element to be overpressed or it can become damaged by sharp component edges.

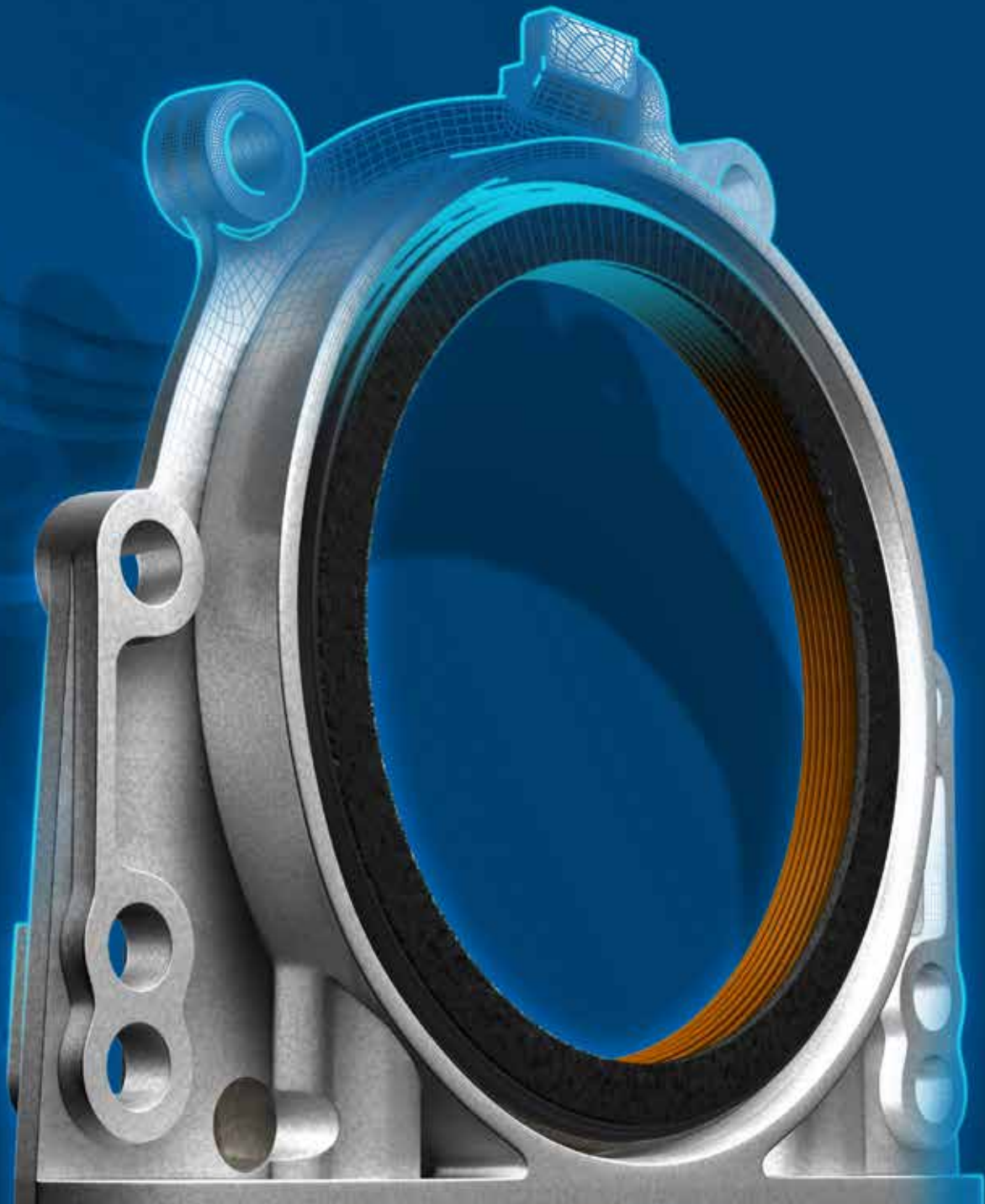

PTFE Oil Seals and Their Installation

Tips and Practical Information No. 4

Dynamic Seals and Oil Seals

Dynamic Seals

The purpose of dynamic seals is to provide sealing between two moving machine components. The most important types are oil seals for use on rotating shafts, and valve stem seals for reducing the flow of oil through the cylinder head into the combustion chamber.

Oil Seals

The purpose of oil seals is to provide sealing between the rotating crankshaft and the outside. Classical oil seals consist of a metal housing that carries the dynamic sealing lip and also provides the static sealing function. The sealing lip of oil seals is usually manufactured of elastomer material, and is in contact with the surface of the rotating shaft. Hereby, the lip is pressed onto the shaft surface by means of a spring ring. As a result of the rotational movement, there is a sealing gap of approx. 1 µm at the lip edge. Oil can enter this gap, which serves to lubricate the sealing lip.

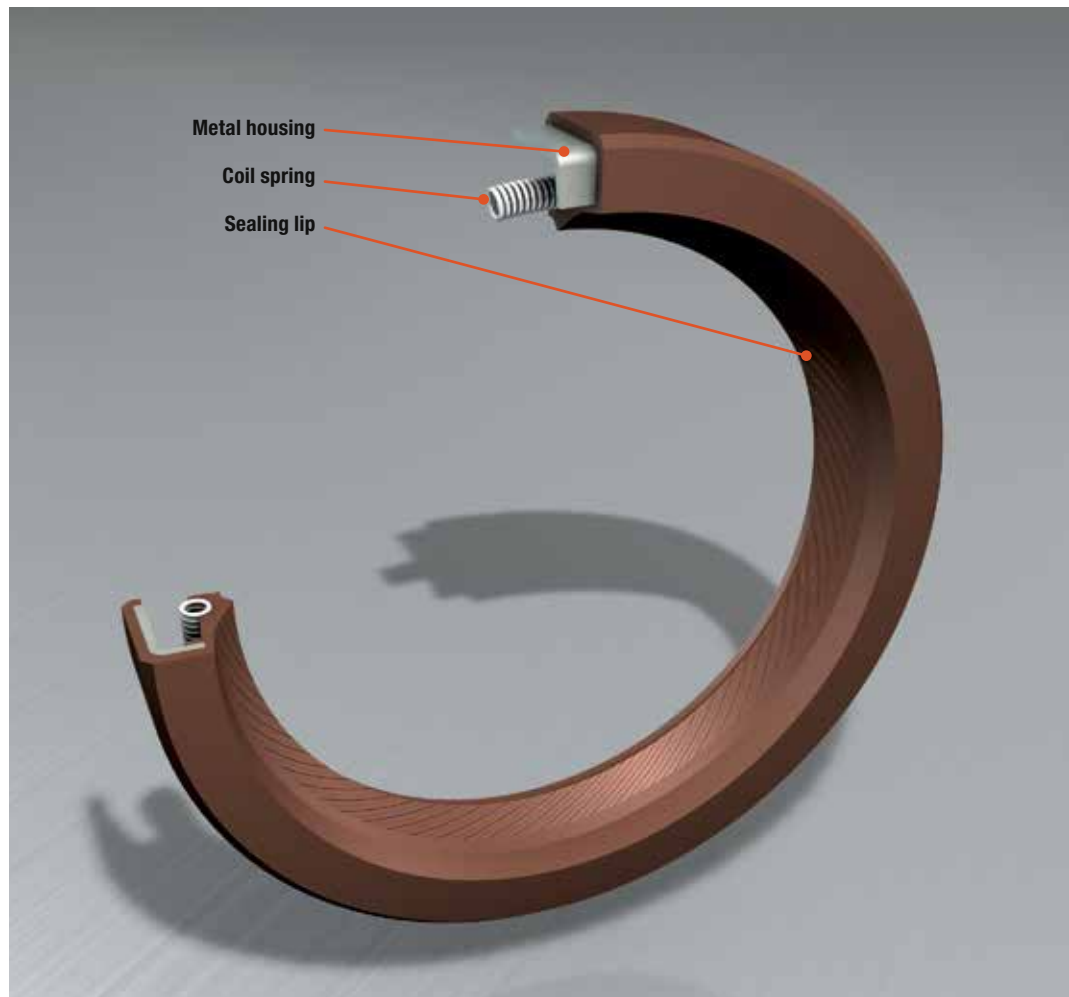

▲ Construction of a conventional oil seal with spring ring.

Dynamic seals may never be completely tight. A lasting sealing function can only be ensured if a defined amount of oil is able to exit for seal lubrication. Heat and attrition are generated by the parts moving against each other. The intentional oil leakage thus prevents seal wear and possible failure. In addition, the dynamic seal must provide a tight static seal between shaft and sealing lip when the shaft is stationary.



A Perfect Combination – Oil Seals and PTFE

New Demands On Oil Seals

Ongoing developments in engine design result in ever-higher demands on this type of seal. Higher engine speeds and oil temperatures, longer intervals between oil changes, and lubricants with modern additives that react aggressively with the sealing materials require new and lasting solutions. The material for future oil seals is named polytetrafluoroethylene – or simply PTFE.

Trend-setting Advantages

Low friction and minimum power consumption are the decisive advantages offered by PTFE oil seals. These seals can be used without problems also with dry operation or insufficient lubrication. The material's excellent thermal properties, with an operating range of -130°C to $+200^{\circ}\text{C}$, are unrivalled. Moreover, PTFE is featured by high chemical resistance and a low breakaway torque after standstill.

PTFE – Material With a Memory

When heated, PTFE attempts to return to its original form. In other words: The material «remembers» its original condition. This phenomenon is known as the plastic memory effect, and permits seals to be built without a pretensioning spring. During manufacture, the sealing lip is shaped as a flat ring, which is molded to the reinforcing ring. During assembly onto the shaft, the initially flat sealing lip expands and folds to match the shaft diameter. As soon as the sealing lip heats up during engine operation, it attempts to return to its original shape.



Polytetrafluoroethylene – PTFE for short – is a fully fluorinated polymer and belongs to the group of polyhalogenated olefins. This synthetic material is best known under the trade names Teflon and Gore-Tex. PTFE was discovered by chance in 1938 by the research chemist Roy Plunkett.

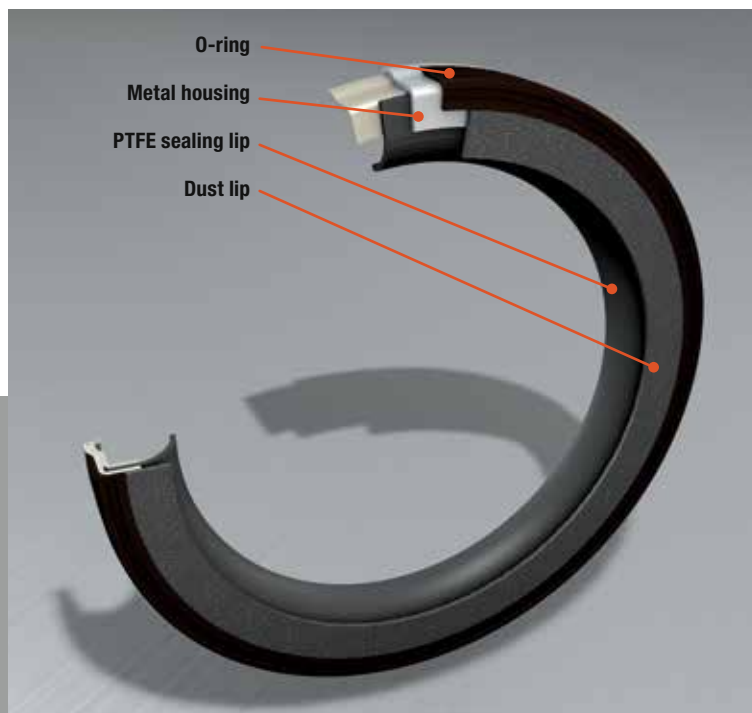

◀ Construction of an oil seal with PTFE sealing lip.

Design and Construction

The outer housing is made of stainless steel. An O-ring of fluoroelastomer ensures optimal static sealing. The internal diameter is perfectly concentric with the outer diameter. The actual sealing lip is made of highly wear-resistant and low-friction PTFE. An additional dust seal (rubber lip or felt strip) provides an effective barrier against contaminating particles.

Special Type With Integrated Oil Seal

Integrated oil seals reduce the manufacturing time of series production engines. As only one component needs to be installed, work on the assembly line as well as subsequent leakage is reduced by about one third. Similarly, significant time savings are achievable when replacing the radial crankshaft seals.

TIP FROM THE EXPERTS

For some engines the oil sump always needs to be detached and newly re-sealed whenever the integrated rotary shaft seals are replaced.

In order to install integrated radial oil seals with sensor technology both correctly and professionally, it is absolutely essential to use the right special tool for the replacement part.

In various OE repair manuals there are extensive disassembly and assembly instructions relating to this topic.

We do not recommend attempting to replace this component without these aids.



◀
Integrated oil seal

Installation of PTFE Oil Seals

As opposed to the installation of conventional oil seals, certain particularities must be observed during the installation of oil seals with PTFE sealing lip.



TIP FROM THE EXPERTS

1. Only remove PTFE oil seals from their protective packaging immediately before installation, to protect them from dust and other contamination.
2. The sealing lip of PTFE oil seals is protected by a plastic sleeve, which can normally be used as an assembly aid. Therefore, the sleeve should remain in place until the seal has been installed.
3. If the seal is to be installed without the sleeve, use the special tool provided by the manufacturer.
4. Both the PTFE sealing lip and the shaft surface must be completely dry. Do not use any grease or oil.
5. The shaft may not exhibit any sharp-edged chamfers – if necessary, have the edges removed by an engine expert.
6. The shaft surface must be in a perfect condition – also here, possible damage must be repaired by an expert.
7. Position the assembly sleeve with the PTFE oil seal on the shaft.
8. Make sure that the sealing ring is aligned correctly – the sleeve must be located so that the seal can be pushed onto the shaft smoothly.
9. Push the sealing ring onto the shaft with an even motion.
10. When replacing, the PTFE lip of the new seal should not run in the same position as the old one.
11. You can now remove the assembly sleeve.
12. Do not start the engine sooner than four hours after installation – this permits the new sealing lip to adapt perfectly to the shaft.

If these practical hints and the manufacturer's recommendations are observed, the PTFE oil seal will give reliable service.

Failure of PTFE Oil Seals

Damaged PTFE Sealing Lip

The most frequent cause for failure is damage to the PTFE sealing lip during assembly. If the seal is installed without the help of a sleeve or special tool, and is shifted or even turned inside out, reliable sealing will hardly be possible. Similarly, the use of oil or grease – as with classical oil sealing rings – will result in total failure of the PTFE oil seal immediately after installation.

You Can Trust the Dana Specialists

The advantages of PTFE technology set new standards in the development of oil seals. Modern engine concepts require solutions for dynamic seals, which are able to withstand the high loads lastingly. Thanks to outstanding properties, PTFE meets these demands – the best prerequisites for series use in modern engines.



▲ Damaged PTFE sealing lip as the cause of failure.



▲ Greased PTFE sealing lip as the cause of failure.

TIP FROM THE EXPERTS

If available, new oil seals with PTFE sealing lip can be used as replacements for conventional oil seals.

Dana offers a complete product range with the new generation of PTFE oil seals. Our latest Victor Reinz product catalogs provide a survey of the available PTFE oil seals.



MLS Cylinder-head Gaskets and Damage Analysis

Tips and Practical Information No. 5

Multi-layer Steel – for the best Cylinder-head Gaskets

Under Extreme Pressure

Victor Reinz® multi-layer steel cylinder-head gaskets set new standards for modern engine design. Thanks to sealing technology at the highest levels of performance and quality, they provide outstanding and efficient results under increasingly tough operating environments – the optimum preconditions for fuel-saving, environmentally compatible mobility.

Innovative cylinder-head gaskets must combine utmost sealing potential with reduced bolt force, low setting losses and low bolt force losses – even with wide bolt spacing – as well as pronounced elasticity and excellent durability. It is precisely these performance characteristics of Victor Reinz® MLS cylinder-head gaskets that make them the optimum solution for present and future engine generations – with lower total weight and reduced rigidity, less installation space, and narrower webs, coupled with higher engine torque and output plus continuously increasing combustion pressures.

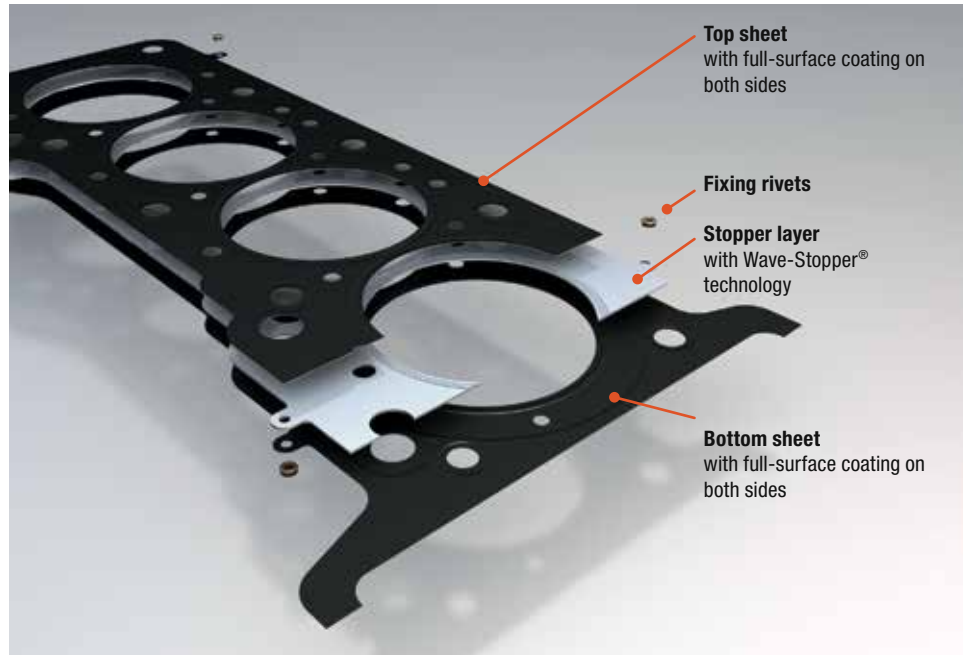

Individual Design

Victor Reinz® MLS cylinder-head gaskets consist of two to five sheets of spring or carbon steel, which are sandwiched with the sealing material to form multi-layer steel cylinder-head gaskets. Shaped beads and stoppers plus the elastic properties of the spring steel increase the local line pressure around the combustion

chamber and in the backland (macro sealing). Complete and partial elastomer coatings provide additional sealing tightness (micro sealing). For extreme application conditions, vulcanized and molded-on elastomer elements ensure reliable sealing in the backland.

In combination with the cylinder-head gasket's quality, it is the surface finish of cylinder head and engine block as well as the gasket's installation that are decisive for good sealing results. Component unevennesses and distortions, reused head bolts, and the use of grease, oil or liquid sealing compounds will deteriorate the sealing effect of even the best MLS cylinder-head gasket. Therefore, the manufacturer's installation instructions must be strictly observed.

▲ Typical three-layer MLS cylinder-head gasket with top sheet, active layer with Wave-Stopper® technology, and bottom sheet. Beads plus full-surface elastomer coatings improve the sealing potential of these modern sealing systems. Beads for macro sealing, and elastomer coating for micro sealing.

Victor Reinz® Solutions for Leaky, Damaged, Defective Elastomers

Damage to Cylinder-head gaskets

MLS cylinder-head gaskets manufactured by Dana are subjected to demanding quality tests during production. Leaks, damage, or total failure of the sealing system are mostly an indication of causes or defects in the engine/gasket system. Consequently, simply replacing the cylinder-head gasket will not automatically solve the problem.

Typical leaks between cylinder head, cylinder-head gasket, and engine block involve gas, oil, or coolant leakages. These leakages occur between combustion chambers, into the coolant circuit, or to the environment. Gas

leaks can result in fatal engine damage within a very short time and oil leaks can cause severe environmental pollution.

Pressed-in dirt or foreign objects as well as rough surfaces also cause damage to cylinder-head gaskets. Component unevenness leads to gas blowby between the combustion chambers, and consequently to gasket failure.

Causal Investigation

Engine overheating in combination with component distortion, or inadequate compression of the cylinder-head gasket are the most frequent reasons for leakage.

Thermal overloading occurs as a result of defective components in the coolant circuit or incorrect maintenance. Other causes are irregular combustion due to coke deposits, and excessively high exhaust gas pressure after failure of the catalytic converter. Moreover, chemical additives in the coolant and low-quality antifreeze agents can attack sealant coatings.

While reworking the surfaces of cylinder head or engine block in case of component unevenness, distortion, waviness, or scores and grooves, dirt and foreign objects accumulate, which can result in damage to the cylinder-head gasket. Therefore, thorough cleaning of the sealing surfaces is essential before installing the cylinder-head gasket.

In professional terminology, leaks between cylinder head, cylinder-head gasket, and engine block all fall under the general term "leakage". This always involves an uncontrolled exit of media (gas, oil, coolant) between cylinder head, engine block, and cylinder-head gasket.

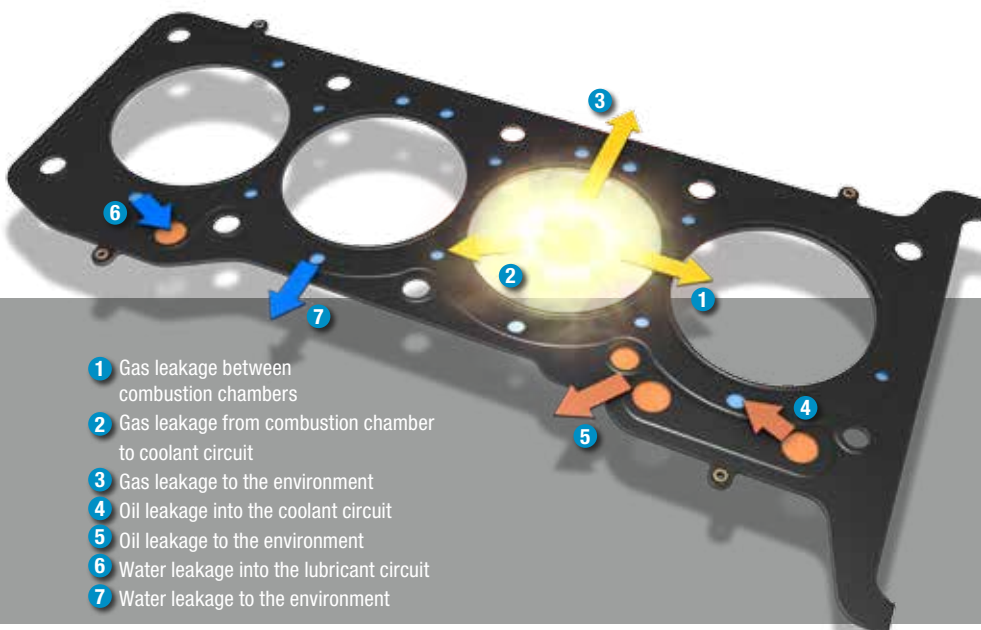

◀ Typical media leakages with MLS cylinder-head gaskets

Fractured Beads and Damaged Elastomers



▲
Broken web caused by high component dynamics



▲
Elastomer coating damaged by overheating

Damage Analysis of MLS Cylinder-head Gaskets

Damage to multi-layer steel cylinder-head gaskets mostly involves two sealing elements: beads and elastomer coatings. The beads can fracture due to various factors, and elastomers can become detached from the substrate material or be scorched. Both of these damage profiles indicate different causes.

Bead Fractures due to excessively high Component Dynamics

Possible causes for excessively high component dynamics are faulty, reused, or unlubricated cylinder-head bolts; incorrect bolt torquing due to excessively high friction during installation; and damage to cylinder head or engine block. Component distortions can also be the result of engine overheating. Similarly, if an engine is operated under pinging conditions (pre-ignition), the high

temperatures and pressures can lead to higher component dynamics and possible bead fractures.

Detached Elastomer Coating due to Overheating

Classical causes for overheating are defects of the water pump, radiator, thermostat or hoses, but also insufficient coolant or incorrect venting of the coolant system can lead to thermal problems. Failure of the catalytic converter can also result in higher temperatures due to increased exhaust back pressure.

TIP FROM THE EXPERTS

If the elastomer coating of a removed defective cylinder-head gasket can be peeled off the metal substrate easily with a fingernail, engine overheating is the most likely cause of the failure.



Elastomers are highly specialized rubber that has been optimized to comply with the specific demands of engines. Their outstanding features include excellent slip characteristics, high resistance to media, and function-optimized flow behavior.

Elastomer scorched by Gas Leaks

During so-called blowby, combustion gases flow from one cylinder to the other via the web, or from a combustion chamber into the coolant circuit. This gas flow “scorches” the elastomer or the elastomer coating in the affected area. The resulting lack of micro sealing leads to disturbances in the combustion process and reduced performance – and to a possible pressure build-up in the coolant circuit. Causes for blowby are excessively high combustion pressures, rough sealing surfaces, component distortions, or inadequate compression of the cylinder-head gasket.

Elastomer Coating destroyed by Antifreeze Agents

Contact with antifreeze agents that have not been approved can cause the elastomer coating



▲
Scorched elastomer coating

to become detached from the metal surface. Subsequently, the dislodged elastomer particles can clog the coolant channels and interrupt the coolant flow. The result is an overheated engine.

Other typical damage profiles for MLS cylinder-head gaskets are destroyed combustion chamber seals due to incorrect cylinder liner protrusion or faulty liner flange seats, as well as severely damaged Ricardo squish areas due to detached swirl chambers.



▲
Damaged gasket in the Ricardo squish area due to detached swirl chamber. Spacer sheet fractured in two places and pressed out.

TIP FROM THE EXPERTS

Cylinder-head bolts tightened using the torque-angle method are elongated permanently. After disassembly, they are clearly longer than new bolts. If reused, they can break. Therefore, new cylinder-head bolts should always be used when replacing a cylinder-head gasket.

Further detailed information about the optimum compression of cylinder-head gaskets is given in the brochure “Practical Information No. 2 – Cylinder-head bolts and cylinder-head installation” issued by Dana. Simply request your personal copy in an e-mail to reinz.service@dana.com.

Tips for a Perfect Seal

Surface Finish

The surface finish of cylinder head and engine block has a decisive effect on the performance potential of MLS cylinder-head gaskets. Principally, the better a surface is, the better will be the sealing effect. Surface roughness R_z should not be greater than 15 μm and R_{max} not greater than 20 μm .

Practical Tip

Before installing the cylinder-head gasket, check the surface finish and remove any dirt and foreign particles with the Victor Reinz sealant remover RE-MOVE. Component unevenness and distortion can be determined by means of a straightedge; waviness (deviations in parallelism) and roughness are detected with the help of a sensing probe. Possible distortions of the component surfaces should be less than 0.1 mm over a measured length of 1000 mm, or less than 0.03 mm within a measured area of 100 x 100 mm. Stay within the specified values, and process/machine the surfaces according to manufacturer specifications.

Cylinder-head Bolts

The choice of suitable cylinder-head bolts and the correct torquing procedure have a lasting effect on the surface pressure quality, and therefore on the perfect compression of the cylinder-head gasket.

Practical Tip

Only so-called stretch bolts (waisted bolts) should be used, which can be torqued beyond their elastic limit into the plastic region. With the torque-angle tightening method, the bolt is tightened further by a defined amount (prevailing angle or torque) after a certain torquing value (pretorque) has been reached – re-torquing of the head bolts is no longer necessary.

Sealing Compounds

MLS cylinder-head gaskets are designed individually to suit specific engines. Beads, stoppers, elastomer coatings, and partially vulcanized or molded-on elements are adapted precisely down to the μm . Additional sealing measures are only required if they are specified explicitly by the manufacturer.

Practical Tip

When installing cylinder-head gaskets, no sealing compounds, grease or oil should ever be used. Sealing compounds will cure and harden, which changes the coating thickness, and results in leaks. What's more, they can flow into oil and coolant channels, where they cause clogging. Sealing compounds applied in the combustion chamber area will burn out and impair the bead's function.

TIP FROM THE EXPERTS

Following the production process, quality experts check the exact layer thickness and profile heights as well as the adhesion properties of the elastomer coatings and sealing elements. When installing a cylinder-head gasket, make absolutely sure not to damage the elastomer coatings and profiles.



Sealants and Sealant Remover

Sealing Made Easier and Faster with REINZOSIL and REINZOPLAST

REINZOSIL

Description

Fast-hardening silicon sealant. Ideal to seal small gaps between flat surfaces.

Features

- High thermal stability from -50 °C to +300 °C (brief peak temperature)
- Very good durability against internal combustion fuels and diesel fuels, bio-diesel, oil, grease, lubricants, water, seawater, sunlight and ozone
- Easy to position and shape
- Easy to apply
- Precise positioning, down to the last millimeter
- Container empties completely, no waste
- Protective cap prevents nozzle from blocking up
- Prevents corrosion of the sealing surfaces
- Acid-free hardening means no damage to synthetic parts, electrical components, etc.
- Hardens faster than other silicon sealants
- Non hazardous
- Odourless
- Can be used on vertical and overhead surfaces

Application areas

Particularly intended for sealing all surfaces in engines, gearboxes, and axles, and also for cylinder liners and synthetic housings. Very suitable for uneven and rough surfaces. All-purpose application for use with all makes of engines and vehicles.

REINZOPLAST

Description

Solvent-free, permanently plastic, non-hardening, polyurethane sealant with high viscosity, for highly-stressed sealing joints without a sealing gap, such as joints that are subject to vibrations.

Features

- Non-hardening
- Easy to disassemble
- Does not crack under pressure from engine vibrations
- High thermal stability from -50 °C to +300 °C (brief peak temperature)
- Very good durability against internal combustion fuels and diesel fuels, oil, grease, lubricant, additives, antifreeze, water and gas
- For wet sealing without a sealing gap
- High viscosity
- Ready for immediate assembly
- Fully loadable within seconds
- Storable for approx. 3 years

Application areas

For micro-sealing finely-tuned components in engines, gearboxes and axles. For sealing threads. For pump station and power station work. All-purpose application for use with all makes of engines and vehicles.

RE-MOVE

Description

Highly effective and long-lasting sealant remover on an ether solvent and propellant base.

Features

- High-adhesion
- Does not drip
- When sprayed, it gives an impermeable, high-adhesion, highly effective liquid film
- Can be used on vertical and overhead surfaces
- Can also be used on sloped and vertical surfaces
- Also suitable for removing resin and paint residue
- Super-quick to use
- Does not damage surfaces

Application areas

For removing gaskets, gasket remnants and sealing compounds. Also for removing glue, resin and paint residue. All-purpose application for use with all makes of engines and vehicles.



Technical Datasheet

www.victorreinz.com/jsi-datasheet

Safety Datasheet

www.victorreinz.com/jsi-datasheet



SPICER®

Axles
Driveshafts
Off-Highway Transmissions

VICTOR REINZ®

Gaskets and Seals
Cylinder-Head Cover Modules
Thermal-Acoustic Protective Shielding

LONG®

Transmission Oil Coolers
Engine Oil Coolers



About Dana Holding Corporation

Dana is an integral partner for virtually every major vehicle and engine manufacturer worldwide. Dana is a leading supplier of drivetrain, sealing, and thermal technologies to the global automotive, commercial-vehicle, off-highway markets and for industrial applications. Founded in 1904, Dana employs thousands of people across five continents.

What Can Dana Do For You?

Dana provides high-quality product solutions. This lineup of technologies from one source is designed to offer flexibility to vehicle manufacturers around the world – whether in automotive centers or emerging markets – and ensures that customers get the latest state-of-the-art technologies, as well as products adjusted for specific local markets. With technology centers strategically located throughout the world, Dana engineers have the superior resources to develop, design, test, and manufacture to suit individual customer needs. This close collaboration allows Dana to create everything from advanced single components to fully integrated modular systems.

Power Technologies Group
REINZ-Dichtungs-GmbH
Reinzstrasse 3-7
89233 Neu-Ulm
Germany
www.victorreinz.com

VICTOR REINZ®

